

Komise pro ocelové konstrukce při MĚR ČSVTS Praha
Komise české rady ČSVTS pro ocelové konstrukce
Dům techniky ČSVTS Pardubice

Výpočetní modely pro navrhování
ocelových konstrukcí

Models for the analysis of steel structures

SEZENÍ

PROCEEDINGS



Pardubice, 25. - 26. dubna 1989
Czechoslovakia

783 901

DI 607

1523 Z

90-02-09098-6

Dr. Károly JÁRMAI

Technical University for Heavy Industry, Miskolc, Hungary

ECONOMIC DESIGN OF SANDWICH BEAMS

Abstract: The sandwich beams with outer layers of box section offer high load-carrying and damping capacity combined with low weight. The models of static and dynamic analysis were verified by experiments. A decision support system has been worked out and used to determine various optima using four objective functions, four unknown variables and fourteen nonlinear inequality constraints.

1. Introduction

Traditionally, we have relied on our experience and intuition to define a proposed design and then used the computer as an analysis tool to judge the quality of the design. This may be expanded in a variety of ways to automate more of the process, still based on a set of "design rules". The design objective, still based on maximum performance, did not play a direct role in the decisions.

Numerical optimization methods offer an alternative to this more traditional design approach. Using these methods, the engineer may choose the objective to be minimized or maximized, can choose a variety of different design variables and can impose a multitude of constraint conditions that must be satisfied at the optimum. No preconceived conditions about the optimum are imposed, leading to the possibility of unique and some-times counter intuitive solutions.

2. Decision support system

The decision support system (DSS) connects the single-criterion and multicriteria optimization methods. The DSS, developed by the author, contains seven various multicriteria optimization methods and seven single-criterion optimization

methods. The structure of the computer code can be seen in Fig.1. The DSS gives the possibility for the designer to collect a great number of so called Pareto optima and choose the best from them [1].

Using the DSS one can change both single- and multicriteria optimization methods, because the efficiency of the algorithms differs greatly for the same problem. Algorithms find discrete optimum, using previously defined discrete values for the variables [2].

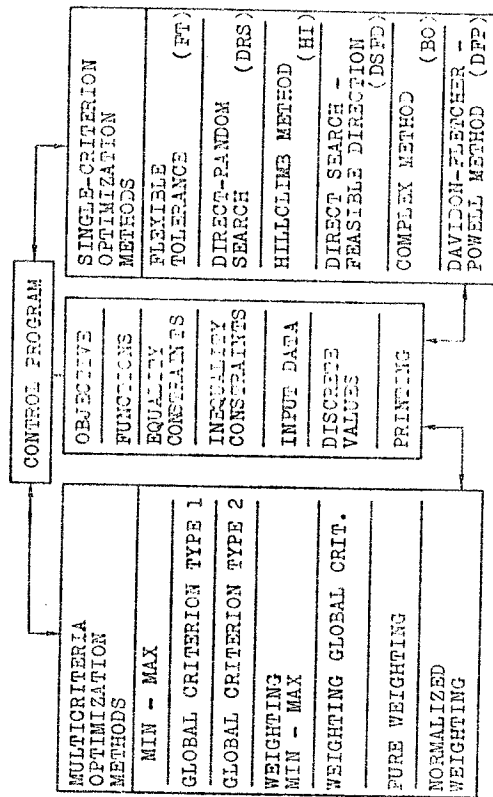

Fig.1.

3. Selection of a model for sandwich beams with box cross sectional faces

It is desirable for all structures to possess sufficient damping to reduce they response to a given excitation. Thus if the damping in a structure is increased there will be a reduction in vibration and noise, and the dynamic stresses in the structure will be reduced with Resulting benefit to the fatigue life.

The analysis is based on assumptions as follows:

- the beam with symmetrical boundary conditions is treated only (simply supported beam)
- the viscoelastic constrained layer is subjected to shear only and its stiffness does not contribute to the total bending stiffness of the structure
- the shear stress in the constrained layer is uniformly distributed across the core
- the core stiffness is enough large to keep the constrained layers distance on the same value, so the beam is characterized with one displacement.

The displacement is distributed into two parts: the primary and secondary ones. The primary displacement is produced by angular displacement occurring in the full cross section, calculated with the total bending stiffness (B_f). The secondary displacement is produced because the cross sections of faces have only vertical displacement against their own bending stiffnesses (B_{f1}), and the core has shearing displacement. Because of this the straight line $a-g$ has a distortion (see Fig.2).

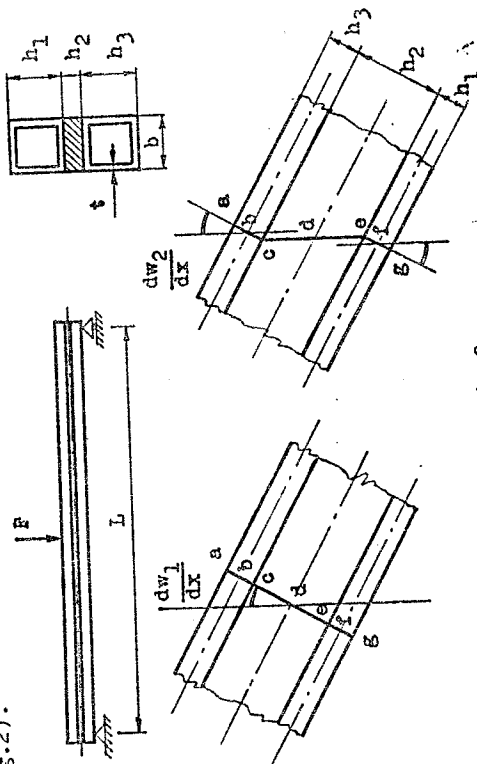

Fig.2.

The maximal deflection for one load at midspan is given by Allen[3]

$$w_{max} = \frac{FL^3}{48B_f} + \frac{FL}{4B_{t2}} \left(1 - \frac{B_{f1}}{B_f}\right)^2 S_1$$

The maximal shear stress in the core is given by

$$\tau_{2max} = \frac{F}{2b(h_1+h_2)} \left(1 - \frac{B_{f1}}{B_f}\right) S_2$$

The maximal normal stress can be expressed as

$$\sigma_{max} = E \frac{FL}{4} \left[\left(h_1 + \frac{b_2}{2}\right) \frac{S_2}{B_f} + \frac{b_1}{2} \frac{1-S_2}{B_{f1}} \right]$$

where $B_{f1} = B_1 + B_3 = 2EI_1$; $B_f = B_{f1} + 2EA_1 y_1^2$

$$B_{t2} = G_s \frac{b}{b_2} (h_1 + h_2)^2; \quad S_1 = 1 - \frac{A_1}{Q}$$

$$S_2 = 1 - \sqrt{1 - \beta_1^2}; \quad S_3 = 1 - \frac{A_1}{Q}$$

$$Q = \frac{1}{2} \left[\frac{B_{f1}}{L^2 B_{t2}} \left(1 - \frac{B_{f1}}{B_f}\right) \right]^{-1/2}$$

For uniformly distributed load and two concentrated forces the equations are given in [3] and [4].

The dynamic characteristics of the sandwich beam can be described by the equation of Mead and Markus [7]

$$\partial^6 w / \partial x^6 - \epsilon_0 (1+Y) \partial^4 w / \partial x^4 = (1/B_f) (\partial^4 p_0 / \partial x^4 - \epsilon_0 p_0)$$

where $p_0 = -m \partial^2 w / \partial t^2 + p(x,t)$

$$\epsilon_0 = 2 G_d b / A_1 E b_2$$

$$Y = \left[(h_1 + h_2)^2 / 2 B_f \right] A_1 E$$

Although this equation was derived for sandwich beams with thin faces, using the recommendations of Yin [8], it can be applied for flexural faces as well. Loss factor of the beam can be described by the following equation.

$$\eta = \frac{\beta XY}{1 + (2+Y)X + (1+Y)(1+\beta^2)X^2}$$

where the shear parameter: $X = \epsilon_0 r_k^2$; $r_k = \frac{CL}{2Y}$

The loss factor of the core material is β . Values of the constant C have been given in [9]. The results of static and dynamic measurements were in good agreement with the calculated values [5].

4. Economic design of sandwich beams

Four objective functions have been chosen:

- cost of aluminum profiles; $c_{AL} = 5 \cdot 10^{-4}$ Ft/mm³
- cost of core; $c_{CC} = 1 \cdot 10^{-4}$ Ft/mm³
- cost of gluing and surface preparation;
 $c_{GL} = 1 \cdot 10^{-3}$ Ft/mm²
- total cost of sandwich beam including the previous ones.

Fourteen inequality constraints have been chosen: constraint on

- Normal stress due to bending at the outer layer
- shear stress at the core
- deflection of the beam
- loss factor of the beam
- local buckling of webs
- local buckling of flanges
- size constraints on independent variables.

Four independent variables have been chosen:

- height of outer layers
- thickness of outer layers
- thickness of the core
- width of the beam.

The effect of the objective functions to each other can be seen in Fig.3-6. Fig.3. shows, that the costs of gluing and core material affect significantly the total cost. So it is on the cost of Al profiles on Fig.4. There is no large effect between the total and Al costs.

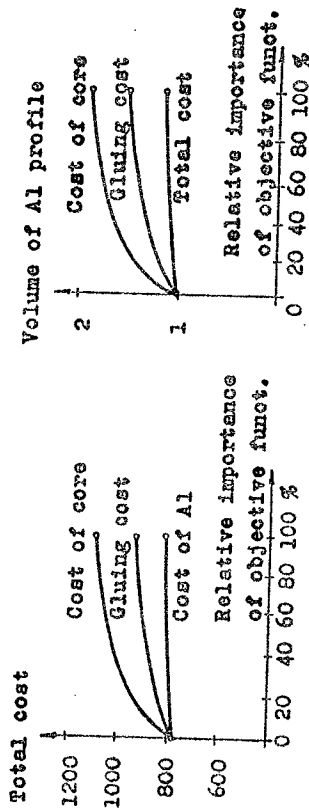

Fig.3.

Fig.5. shows, that the cost of Al affects significantly the cost of core. It is because of the demand of moment of

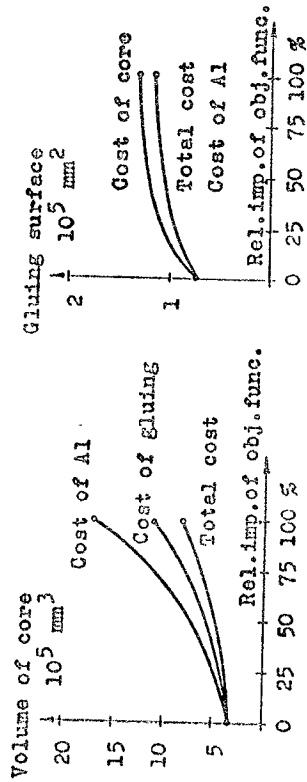

Fig.5.

inertia. The cost of core increases more than six times with the decreasing the cost of Al profiles. Fig.6. shows that the total cost and the cost of Al profiles affect significantly the surface preparation and gluing costs.

Using various weighing parameters the designer can find a great number of so called Pareto optima, and he can choose his best optimum using various aspects such as aesthetic, construction, etc.

Iskra G. Nesheva

Centre for Computer Aided Building Design and Management, Sofia

NON-LINEAR ELASTOPLASTIC ANALYSIS OF STEEL PLANE FRAME STRUCTURES

Abstract: The wide application of computer technique and advanced numeric methods lately has given further rise to taking into consideration the nonlinear behaviour of structures. In the paper the model and the algorithm for a step wise solution of steel plane frame structures with incremental loading, taking into account both geometrical and material nonlinearity is described. The main purpose is achieving more accurate calculation of the ultimate strength and stability of structures.

An attempt is made to describe the experience in CESSI in implementing new methods for analysis of non-linear behaviour of steel structures under the tutorship of prof. S.V.Simeonov.

The purpose of this study is to provide the possibility to consider the following cases:

- a deflected geometric scheme of the structure in elastic state;
- elasto-plastic properties of the material when geometric linearity is assumed;
- the strain and stress state when double non-linearity is available;
- the unloading at every step of load increment.

The material nonlinearity is taken into account according to the deformation theory of plasticity. The nonlinear relationship between the stress and the strain is introduced by a realistic

References

- [1] Jármai, K.: Single- and multicriteria on optimization as a tool of decision support system. Computers in Industry (under publication).
- [2] Jármai, K.: Optimal design of welded frames by complex programming method. Publ. of the Techn. Univ. Series C. Machinery. 1982. Vol. 37. pp. 79-97.
- [3] Allen, H. G.: Analysis and design of structural sandwich panels. 1969. Pergamon Press. Oxford.
- [4] Grosskopf, P., Winkler, Th.: Auslegung von GPK/Hertschaun-Verbundwerkstoffen. Kunststoff Bd. 63. H.12. 1973. pp. 881-888.
- [5] Parkas J., Jármai, K.: Structural synthesis of sandwich beams with outer layers of box-section. Journal of Sound and Vibration. Vol. 84. No. 1. 1982. pp.47-56.
- [6] Jármai, K.: Economic design of metal structures. Candidate of Science Dissertation. 1988. Techn. Univ. for Heavy Ind. Miskolc, Hungary (in Hungarian).
- [7] Mead, D.J., Markus, S.: The forced vibration of a three-layer damped, sandwich beam with arbitrary boundary conditions. Journal of Sound and Vibration. Vol. 10. 1969. pp. 163-175.
- [8] Yin, T.P., Kelly, T.J., Barry, J.E.: A quantitative evaluation of constrained-layer damping. Journal of Engineering for Industry. Vol. 89. 1967. pp. 773-784.