

STABILITY OF STEEL STRUCTURES 1990, Budapest

Volume 2

Edited by

M. IVÁNYI

Professor of Structural Engineering
Department of Steel Structures
Technical University of Budapest, Hungary

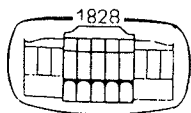

Akadémiai Kiadó, Budapest

FARKAS, JÓZSEF (1)
JÁRMAI, KÁROLY (2)

MINIMUM CROSS-SECTIONAL AREA DESIGN
OF CENTRALLY COMPRESSED STRUTS OF SQUARE BOX SECTION
WITH LONGITUDINAL STIFFENERS

STABILITY OF STEEL STRUCTURES
BUDAPEST, HUNGARY, 1990
XII. COLD FORMED MEMBERS AND
INTERACTIVE BUCKLING
CONTRIBUTION

Summary: An optimum design procedure is presented in which the four unknown dimensions of a square box section with longitudinal flat stiffeners are sought. The cross-sectional area should be minimized and constraints on overall and local buckling have to be fulfilled. The interaction of overall and local buckling is considered by a simple formula proposed by Nakai et al. The optimization is performed by the use of a computer program worked out on the basis of Rosenbrock's direct search method. The required cross-sectional areas for unstiffened and stiffened sections are given in graphical form and compared to each other. Steels of yield stress 235 and 355 MPa, respectively, are taken into account. The rounded dimensions of stiffened sections are given in tables.

1. Introduction

The best way for decreasing the weight of steel structures is the decrease of the thickness of their plate elements. This decrease may lead to interaction of overall and local buckling in compression members. The optimum design of centrally and eccentrically compressed struts of square hollow section without longitudinal stiffeners has been worked out by the first author (Farkas 1983, 1984). This optimization has been performed by the use of the Liège-method (Braham et al. 1980) which considers the interaction of overall and local buckling.

Box sections with longitudinal stiffeners have been treated by Nakai et al. (1986) with relatively simple formulae suitable for optimum design. The aim of the present paper is to apply this method to the minimum weight design of longitudinally stiffened box sections. Nakai et al. (1986) gave a calculation method for rectangular box sections subject to com-

(1) Professor of Metal Structures, DSc.

(2) Scientific research worker, CSc. Technical University, Miskolc, Hungary.

pression and bending, symmetrically stiffened with more equally spaced longitudinal ribs as shown in Fig. 1a. The yield stress of plate and stiffener elements may be different. This method considers the interaction of overall and local buckling as well as the interaction of local buckling of plate elements.

For the sake of simplicity we treat here the section shown in Fig. 1b. with square symmetry, considering only four ribs. The strut is simply supported at both ends and subject to pure compression. The yield stress of plate elements and stiffeners is equal, 235 and 355 MPa, respectively. In this case the interaction of local buckling of plate elements may be neglected but the interaction of overall and local buckling should be taken into account.

2. Objective function and constraints

The unknown dimensions b , t , h_s and t_s should be optimized (Fig. 1b) to minimize the cross-sectional area

$$A = 4(bt + h_s t_s) \quad (1)$$

or with non-dimensionalized unknowns

$$x_1 = 100b/L; \quad x_2 = 100t/L; \quad x_3 = 100h_s/L \quad \text{and} \quad x_4 = 100t_s/L$$

$$10^4 A/L^2 = 4(x_1 x_2 + x_3 x_4) \quad (2)$$

and to fulfil the design constraints as follows.

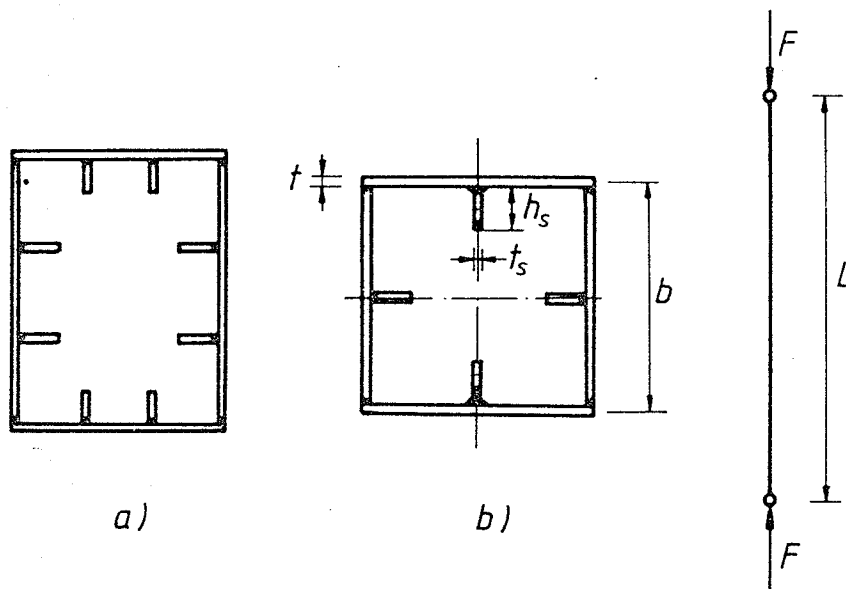

Fig. 1. Centrally compressed strut of a) rectangular and b) square box section with longitudinal stiffeners

Constraint on overall buckling for the factored compressive force

$$F \leq \min \begin{cases} k\sigma_y A \\ k\sigma_y A k_{\text{int}} \end{cases} \quad (3a)$$

$$(3b)$$

where σ_y is the yield stress. Note that the Japanese Specifications (1987) give for steels with yield stress 235 and 355 MPa allowable stresses 140 and 210 MPa, respectively. Furthermore, k is the overall buckling factor

$$k = 1.0 \quad \text{when} \quad \bar{\lambda} \leq 0.2 \quad (4a)$$

$$k = 1 - 0.545(\bar{\lambda} - 0.2) \quad \text{when} \quad 0.2 \leq \bar{\lambda} \leq 1.0 \quad (4b)$$

$$k = 1/(0.773 + \bar{\lambda}^2) \quad \text{when} \quad \bar{\lambda} \geq 1.0 \quad (4c)$$

where

$$\bar{\lambda}^2 = A\sigma_y/F_e; \quad F_e = \pi^2 EI/L^2 \quad (5)$$

or in transformed form using (2)

$$\bar{\lambda}^2 = \frac{10^8 \sigma_y A/L^2}{10^8 \pi^2 EI/L^2} = \frac{10^4 \sigma_y}{\pi^2 E} \cdot \frac{10^4 A/L^2}{10^8 I/L^2} \quad (6)$$

$$I = \frac{2}{3} b^3 t + \frac{h_s^3 t_s}{6} + 2h_s t_s \left(\frac{b}{2} - t - \frac{h_s}{2} \right)^2 \quad (7)$$

Considering (7), (6) may be written in the following form

$$\bar{\lambda}^2 = \frac{4 \times 10^4 \sigma_y}{\pi^2 E} \cdot \frac{x_1 x_2 + x_3 x_4}{\frac{2}{3} x_1^3 x_2 + \frac{1}{6} x_3^3 x_4 + 2x_3 x_4 \left(\frac{x_1}{2} - x_2 - \frac{x_3}{2} \right)^2} \quad (8)$$

Taking $E = 2.06 \times 10^5$ MPa, $\sigma_y = 235$ and 355 MPa we obtain

$$4 \times 10^4 \sigma_y / (\pi^2 E) = 4.62339 \quad \text{and} \quad 6.98428, \text{ resp.} \quad (8a)$$

The factor k_{int} expresses the interaction of overall and local buckling according to Nakai et al. (1986)

$$k_{\text{int}} = k_p + 0.2304 \bar{\lambda}^2 \quad (9a)$$

where

$$k_p = 1.0 \quad \text{when} \quad R \leq 0.31 \quad (9b)$$

$$k_p = 1.14 - 0.454 R \quad \text{when} \quad 0.31 \leq R \leq R_{\text{max}} \quad (9c)$$

$$R = \frac{b}{nt} \sqrt{\frac{12(1 - \mu^2)}{k_0 \pi^2}} \sqrt{\frac{\sigma_y}{E}} \quad (10)$$

where n is the number of panels separated by stiffeners, in our case in Fig. 1b. $n = 2$. With values $k_0 = 4$, $\mu = 0.3$, and $E = 2.06 \times 10^5$ MPa we obtain for $\sigma_y = 235$ MPa

$$R = b/(112t) = x_1/(112x_2); \quad R_{\max} = 0.8 \quad (11a)$$

and for $\sigma_y = 355$ MPa

$$R = x_1/(88x_2) \quad (11b)$$

For a box section without stiffeners ($n = 1$) it is

$$\text{for } \sigma_y = 235 \text{ MPa} \quad R = x_1/(56x_2); \quad R_{\max} = 1.0 \quad (11c)$$

$$\text{and for } \sigma_y = 355 \text{ MPa} \quad R = x_1/(44x_2) \quad (11d)$$

Limitation of the R-value i. e. allowable b/t -ratio of a stiffened or unstiffened plate restrained along two edges

$$R \leq R_{\max} \quad (12)$$

Constraint of local buckling of plate elements

$$F \leq k_p A \sigma_y \quad (13)$$

where k_p is given by (9).

Constraints on buckling of longitudinal stiffeners according to Nakai et al. (1986) and the Japanese Specifications (1987):

$$\text{for } \sigma_y = 235 \text{ MPa} \quad h_s/13.1 \leq t_s \quad (14a)$$

$$\text{for } \sigma_y = 355 \text{ MPa} \quad h_s/10.7 \leq t_s \quad (14b)$$

$$I_L = \frac{h_s^3 t_s}{3} \geq \frac{bt^3}{11} \gamma_{L\text{req}} \quad (15)$$

and

$$A_L = h_s t_s \geq \frac{bt}{10n} \quad (16)$$

1) when

$$\alpha = a/b \leq \alpha_0 = \sqrt[4]{1 + n\gamma_L} \quad (17)$$

and the moment of inertia of a transverse stiffener is

$$I_T \geq \frac{bt^3}{11} \cdot \frac{1 + \gamma_{L\text{req}}}{4\alpha^3} \quad (18)$$

then, for

$$t \geq t_0 \quad \gamma_{L\text{req}} = 4\alpha^2 n \left(\frac{t_0}{t} \right)^2 (1 + n\delta_L) - \frac{(\alpha^2 + 1)^2}{n} \quad (19a)$$

for

$$t < t_0 \quad \gamma_{L\text{req}} = 4\alpha^2 n(1 + n\delta_L) - \frac{(\alpha^2 + 1)^2}{n} \quad (19b)$$

2) other than in 1)

$$\text{for } t \geq t_0 \quad \gamma_{L\text{req}} = \frac{1}{n} \left[\left\{ 2n^2 \left(\frac{t_0}{t} \right)^2 (1 + n\delta_L) - 1 \right\}^2 - 1 \right] \quad (20a)$$

$$\text{for } t < t_0 \quad \gamma_{L\text{req}} = \frac{1}{n} \left[\left\{ 2n^2 (1 + n\delta_L) - 1 \right\}^2 - 1 \right] \quad (20b)$$

$$\text{where for } \sigma_y = 235 \text{ MPa} \quad t_0 = b/(28n) \quad (21a)$$

$$\text{for } \sigma_y = 355 \text{ MPa} \quad t_0 = b/(22n) \quad (21b)$$

a is the spacing of transverse stiffeners,

$$\delta_L = \frac{AL}{bt} = \frac{h_s t_s}{bt} = \frac{x_3 x_4}{x_1 x_2} \quad (22)$$

The spacing a is taken here so that $\alpha = \alpha_0$ and it is assumed that (18) is fulfilled, thus, formulae (19) are used. When the non-dimensionalized unknowns are applied, then x_1, x_2, x_3 and x_4 should be used instead of b, t, h_s and t_s , respectively, in (15)–(20).

$$\text{Size constraints: } x_i^L \leq x_i \leq x_i^U; \quad i = 1, \dots, 4 \quad (23)$$

The lower and upper limit values x_i^L and x_i^U resp., are taken according to the minimal and maximal values of unknowns as follows (in mm):

	min	max		Δ
		$\sigma_y = 235$	355 MPa	
b	50	1400	1400	10
t	2	20	25	2*
h_s	20	200	200	5
t_s	2	16	20	2

* between 22 and 25 $\Delta = 3$.

Δ is the step value considered in the discretization to obtain rounded optimal values.

3. Optimization and results

The optimal dimensions have been computed by the use of a program developed on the basis of the Rosenbrock's direct search method (Rosenbrock 1960, Jármai 1989). First the unrounded optimal values have been found and then the computation has been completed by a discretization procedure to obtain rounded optimal values.

Fig. 2. shows the graphical representation of results. The lines have been determined using computed unrounded optimal values. It can be seen that the relationships $A/L^2 - F/L^2$ may be characterized in a log-log coordinate-system by straight lines. The rounded optimal values for stiffened box sections with yield stress 235 and 355 MPa, respectively, are given in Table 1 and 2.

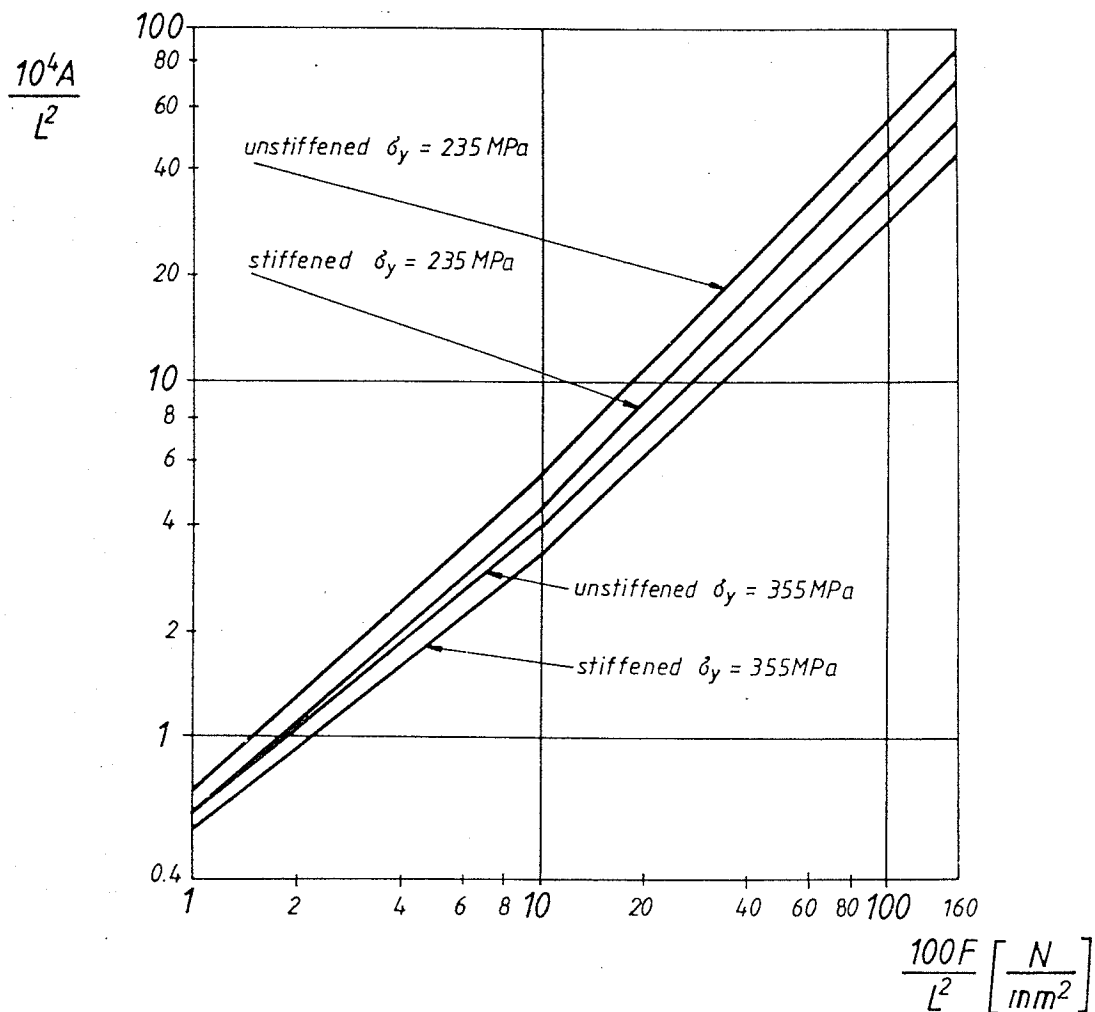

Fig. 2. Optimal cross-sectional areas A/L^2 versus F/L^2 for unstiffened and stiffened box sections with yield stresses 235 and 355 MPa respectively

4. Conclusions

The method proposed by Nakai et al. (1986) complemented by the formulae given in the Japanese Specifications (1987) is suitable for optimum design of compressed struts of

Table 1. Rounded optimal dimensions of box sections, yield stress 235 MPa

L [m]	$F \times 10^{-3}$ [kN]	b	t	h_s	t_s	A [mm ²]
		[mm]				
10	21	1050	20	200	16	96 800
	16	870	20	130	10	77 120
	11	890	14	150	12	57 600
	6	460	14	40	12	31 680
	1	350	4	45	4	6 320
8	21	1050	20	200	16	96 800
	16	870	20	130	10	77 120
	11	890	14	150	12	57 600
	6	450	14	60	10	28 880
	1	320	4	40	4	5 840
6	21	1050	20	200	16	96 800
	16	870	20	130	10	77 120
	11	890	14	150	12	57 600
	6	400	16	45	10	28 640
	1	310	4	40	4	5 760
4	21	1050	20	200	16	96 800
	16	880	18	165	14	72 600
	11	840	14	130	14	56 560
	6	400	16	45	10	28 640
	1	240	4	40	6	4 800

Table 2. Rounded optimal dimensions of box sections, yield stress 355 MPa

L [m]	$F \times 10^{-3}$ [kN]	b	t	h_s	t_s	A [mm ²]
		[mm]				
10	21	740	20	130	14	66 480
	16	640	18	120	12	51 840
	11	490	16	115	18	39 640
	6	430	12	75	8	23 040
	1	350	4	40	4	6 240
8	21	740	20	130	14	66 480
	16	640	18	120	12	51 840
	11	520	14	95	14	34 440
	6	430	12	75	8	23 040
	1	280	4	40	4	5 120
6	21	740	20	130	14	66 480
	16	420	25	150	16	51 600
	11	470	16	60	14	33 440
	6	410	12	60	12	22 560
	1	280	4	40	4	5 120
4	21	740	20	130	14	66 480
	16	410	22	165	18	47 960
	11	390	20	65	8	33 280
	6	310	12	110	12	20 160
	1	160	6	20	6	4 320

longitudinally stiffened box section. The method considers the interaction of overall and local buckling.

The comparison of the minimal cross-sectional areas required for unstiffened and stiffened struts shows that one can achieve approximately 15% savings in weight using flat stiffeners.

The calculations show that, for $10^2 F/L^2 \geq 10$, the optima lay in overall plastic buckling zone, because the compressive stresses F/A are in these cases larger than $0.75 \sigma_y$. Thus the use of higher-strength steel decreases very effectively the weight, the savings in weight may be 40% or more.

References

- Braham, M. , Grimault, J. P., Massonnet, Ch., Mouty, J. and Rondal, J. (1980) Buckling of thin-walled hollow sections. Cases of axially loaded rectangular sections. *Acier-Stahl-Steel*, 45, No. 1. 30–36.
- Farkas, J. (1983) *Optimum square hollow sections for centrally and eccentrically compressed steel members*. 3rd Internat. Colloquium on Stability of Metal Structures, Paris. CTICM, Final Report, 121–125.
- Farkas, J. (1984) *Optimum design of metal structures*. Budapest. Akadémiai Kiadó, Chichester, Ellis Horwood.
- Japanese Specifications for Highway Bridges* (1987). Part 2. Steel bridges. English edition. Japan Road Association.
- Jármai, K. (1989) Single- and multicriteria optimization as a tool of decision support system. *Computers in Industry* 11, 249–266.
- Nakai, H., Kitada, T. and Miki, T. (1986) On a design criterion for checking ultimate strength of thin-walled steel frames. *Mem. Fac. Eng. Osaka Univ.* 27, 245–269.
- Rosenbrock, H. H. (1960) An automatic method for finding the greatest or least value of a function. *Computer J.* 3, No. 3. 175–184.