



Fabrication cost calculations and minimum cost design of welded structural parts

by J. Farkas and K. Jármai (Hungary)

1. Introduction

The economy of welded structures plays an important role in research and production, therefore it is included in the work of IIW Commission XV. It needs the cooperation of designers and manufacturers, so it is a main task for the new Subcommission XV-F "Interaction of design and fabrication".

The decrease of costs may be achieved by various ways. One efficient way is to use mathematical optimization methods. In structural optimization, the version is sought which minimizes the objective function and fulfils the design constraints [1]. As an objective function, the mass (weight) is often defined, but minimum weight design does not give the optimal version for minimum cost. Therefore, a more complex cost function should be defined including not only the material but also the fabrication costs.

In industry it is common to use the cost/tonne concept [2], but this is not suitable for optimization. If we use a cost/tonne cost factor for fabrication cost, then the material and fabrication costs will give similar, non-conflicting functions, which do not lead to an optimum. To find an optimum we need conflicting functions; thus, we should use a more suitable fabrication cost calculation method based on a more detailed cost analysis.

In recent publications [3-5], the first author has used a relatively simple cost function proposed by Pahl and Beelich [6]. These authors have given the production times only for SMAW (shielded metal arc welding) and GMAW-C (gas metal arc welding with CO₂). To apply the cost calculations to other welding technologies, mainly for SAW (submerged arc welding), the COST-COMP [7] software has been used [8]. The values of COST-COMP enable us to define cost functions for different welding technologies.

The aim of the present study is to apply the minimum cost design procedure for simple welded structures to show the effect of fabrication cost on the optimal sizes of a structure by cost comparisons.

2. Survey of selected literature

Some publications in this field have been mentioned earlier by the first author [9]. Relative cost factors for different welded joints have been given by Donnelly [10]. Likhtarnikov [11] has analysed the fabrication times and costs for various building structures.

Aichele's book [12] contains many useful welding cost data and aspects of economic design of welded structures. In Peurifoy's book [13] cost data can be found for welded joints. Volkov [14] has given formulae and factors for fabrication time calculations of roof trusses, columns and crane runway girders of industrial buildings. Yeo [15] published a formula and factors for the calculation of welding costs. Winkle and Baird [16] have investigated the fabrication cost of stiffened plates used in ship structures.

The article of Drews and Starke [17] deals with the economy of robotization. The efficiency of automation should be increased by reducing the time of fixturing, tooling, programming and testing. Horikawa *et al.* [18] proposed various modifications in structural design for efficient application of welding robots. The study of Fern and Yeo [19] compared the effective deposition rates of various semi-automated and mechanised welding processes considering flat, horizontal, vertical and overhead welding positions. Helpful hints have been given to improve design. Chalmers [20] dealt with fabrication costs of ship structures analysing the material and labour costs and giving useful comments for design.

Forde *et al.* [21] have treated the design/fabrication interaction and have proposed an information system to give designers more information about costs. Sen *et al.* [22] have treated the minimum weight and cost design of stiffened, corrugated and sandwich panels used in ship structures, but a detailed cost analysis was not given. The study of Malin [23] gives a good view of the effective automation of welding operations and describes some economic aspects for automation. Pedersen and Nielsen [24] have treated the minimum weight and cost design of a stiffened plate used in ships considering also the cost of welding without any cost analysis. Ramirez and Touran [25] have described the EXSYS expert system which has two main modules. The first module selects an appropriate welding method and the second one estimates the welding costs.

3. Calculation of fabrication costs

The total cost of a structure can be calculated as

$$K = k_m + K_f + K_{add} \quad (1)$$

where K_m is the material cost, K_f is the fabrication cost and K_{add} are additional costs of non-destructive testing, repair, painting, corrosion protection, transportation, erection, maintenance, etc.

Considering only K_m and K_f , Eq. (1) can be written in the form

$$\frac{K}{k_m} = \rho V + \frac{k_f}{k_m} \sum_i T_i \quad (2)$$

where k_m and k_f are the material and fabrication cost factors,

IIW/IIW-1264-94 (ex. doc. XV-847-94) recommended for publication by IIW Commission XV "Fundamentals of design and fabrication of welding" as the authors' own work.

J. Farkas and K. Jármai are with the University of Miskolc, Hungary.



respectively, ρ is the material density, V is the volume of the structure and T_i are the times necessary for fabrication. T_i can be divided in three parts treated as follows.

3.1. Cost of preparation, assembly and tacking

For a plated structure consisting of κ elements the time for this part of fabrication is proportional to the perimeter, for the i th element it is

$$T_i = c_1 P_i$$

The mass of an element is proportional to the square of the perimeter

$$G_i = c_2 P_i^2$$

thus $P_i = c_3 \sqrt{G_i}$ and $T_i = c_4 \sqrt{G_i}$

For the total structure, on average, it is $G = \kappa G_i$ and

$$T_i = \kappa T_i = c_5 \kappa \sqrt{\frac{G}{\kappa}} = c_6 \sqrt{G \kappa}$$

This formula has been derived in Likhtarnikov's book [11] and applied by Pahl and Beelich [6] in the form

$$T_i = C_1 \delta \sqrt{G \kappa} \quad C_1 = 1.0 \text{ min/kg}^{0.5} \quad (3)$$

δ is a difficulty factor, proposed values for it are given in Table 1.

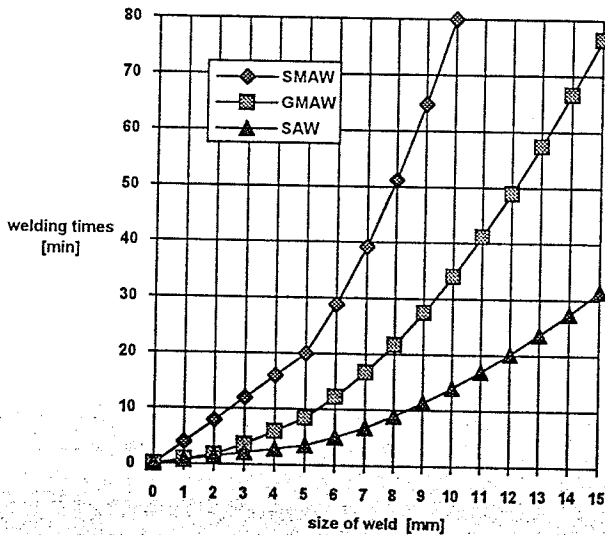

Fig. 1. Welding times for fillet welds of size a_w

Table 1. Proposed values for the difficulty factor δ . For skewed angle joints add 1-2 points

Structures	Welds	V-Weld 60°	Fillet weld 90°
Planar	Long welds flat position	1.0	2.0
Spatial	Short welds plate, flat steel	1.5	2.5
Spatial	U-, L-profiles tubes	2.0	3.0
Spatial	I-, T-profiles	2.5	4.0

3.2. Cost of welding

$$T_2 = \sum_i C_{2i} a_{wi}^n L_{wi} \quad (4)$$

where a_w is the weld size, L_w is the weld length, C_2 and n are constants given for different welding technologies. Values of C_2 and n may be given according to COSTCOMP [7] as follows. The COSTCOMP software gives welding times and costs for different welding technologies. To show the advantages of automation, the manual SMAW, semi-automatic GMAW-C and automatic SAW methods are selected for fillet and 1/2 V butt welds. The analysis of COSTCOMP data resulted in constants given in Figs 1 and 2 and Table 2.

It should be noted that in values for SAW a multiplying factor of 1.7 is considered since in COSTCOMP different cost factors are given for various welding methods.

3.3. Time for changing the electrode, deslagging and chipping

$$T_3 = \sum_i C_{3i} a_{wi}^n L_{wi} \quad (5)$$

Ott and Hubka [26] proposed to use values of

$$C_3 = (0.2-0.4) C_2, \text{ on average } C_3 = 0.3 C_2$$

thus

$$T_2 + T_3 = 1.3 \sum_i C_{2i} a_{wi}^n L_{wi} \quad (6)$$

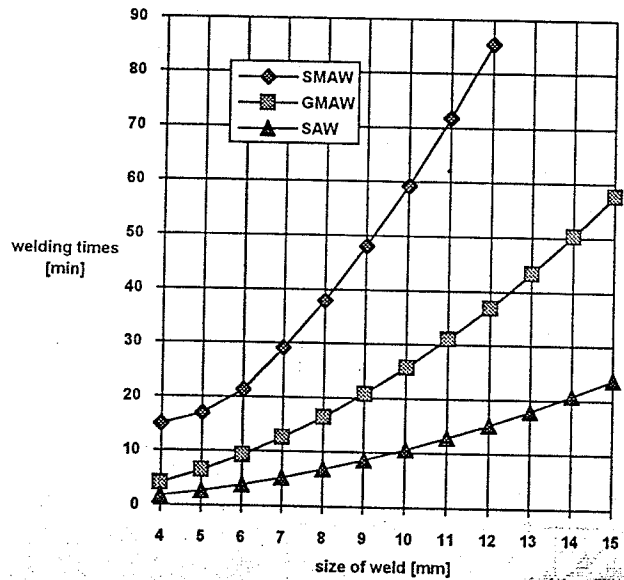

Fig. 2. Welding times for 1/2 V butt welds of size a_w

Table 2. Welding times T_2 (min/mm) as a function of weld size a_w (mm) for longitudinal welds, downhand position (see also Figs 1 and 2)

Weld type	Welding method	a_w (mm)	$10^3 T_2 = 10^3 C_2 a_w^n$
Fillet	SMAW	2-5	$4.0 a_w$
		5-15	$0.8 a_w^2$
Fillet	GMAW-C	2-5	$1.70 a_w$
		5-15	$0.34 a_w^2$
Fillet	SAW	2-5	$1.190 a_w$
		5-15	$0.238 a_w^2$
1/2 V butt	SMAW	4-15	$0.600 a_w^2$
1/2 V butt	GMAW-C	4-15	$0.257 a_w^2$
1/2 V butt	SAW	4-15	$0.181 a_w^2$

3.4. Other cost components

Calculations show that the cost of the electrode can be neglected. The cost of surface preparation and painting, as has been illustrated in the first author's paper [9], significantly affects the optimal sizes of structures. In the mentioned study the painting cost factor $k_p = 12 \text{ \$/m}^2$ has been considered according to literature sources.

4. Numerical examples

In order to show the effect of various welding methods on the optimal sizes and cost of welded structures, two illustrative numerical examples are worked out and the structural versions optimized for various welding methods are compared to each other.

4.1. Welded box beam (Fig. 3)

To simplify the calculations the transverse diaphragms are neglected. The box girder is subjected to a fluctuating load, so the maximal bending moment pulsates between 0 and M_{\max} ; the number of cycles is $N = 2 \times 10^6$.

Two structural versions are considered as follows: (1) the box beam is welded by four fillet welds (Fig. 3a), (2) the webs are welded to the flanges by 1/2 V butt welds (Fig. 3b). All welds are longitudinal and welded in downhand position. For both cases SMAW, GMAW-C and SAW methods are taken into account.

The total cost to be minimized is, according to Eqs (2), (3), (6)

$$\frac{K}{k_m} = \rho LA + \frac{k_f}{k_m} (\delta \sqrt{\kappa \rho LA} + 1.3 C_2 a_w^n L_w) \quad (7)$$

where

$$A = ht_w + 2bt_f$$

$\delta = 3$, $\kappa = 4$, $L = 20 \times 10^3 \text{ mm}$, $L_w = 4L$, $\rho = 7.85 \times 10^{-6} \text{ kg/mm}^3$, $C_2 a_w^n$ are calculated according to Table 2.

To produce internationally usable solutions, the following ranges of k_m and k_f are considered. For steel Fe 360 $k_m = 0.5\text{--}1.2 \text{ \$/kg}$, for fabrication including overheads $k_f = 15\text{--}45 \text{ \$/manhour} =$

0.25–0.75 $\text{\$/min}$. Thus, the ratio k_f/k_m may vary in the range of 0–1.5 kg/min . The value $k_f/k_m = 0$ corresponds to the minimum weight design.

Design constraints are formulated according to Eurocode 3 [27].

Fatigue stress constraint

$$\Delta\sigma = \frac{\Delta M}{W_x} \leq \frac{\Delta\sigma_c}{\gamma_f}, \quad \Delta M = \frac{M_{\max}}{2} \quad (8)$$

$$\Delta M = 15 \times 10^8 \text{ Nmm.}$$

The safety factor against fatigue for accessible joints, non-fail-safe structure is $\gamma_f = 1.25$.

The fatigue stress range $\Delta\sigma_c$ for $N = 2 \times 10^6$ has to be chosen for the corresponding detail category. For longitudinal fillet or butt welds containing stop/start positions (SMAW, GMAW) $\Delta\sigma_c = 100 \text{ MPa}$, for automatic butt welds made from one side only, with backing bar, but without stop/start positions (SAW) $\Delta\sigma_c = 112 \text{ MPa}$. The moment of inertia and the section modulus are given by

$$I_x = \frac{h^3 t_w}{12} + 2 b t_f \left(\frac{h + t_f}{2} \right)^2; \quad W_x = \frac{I_x}{(h + t_f)/2} \quad (9)$$

Local buckling constraints for plate elements using the limiting plate slenderness concept are as follows.

For webs

$$\frac{t_w}{2} \geq \beta_w b; \quad \beta_w = \frac{1}{124\epsilon} \quad (10)$$

For compressed flange

$$t_f \geq \delta_f b; \quad \delta_f = \frac{1}{42\epsilon} \quad (11)$$

To avoid too thick flange plates an additional restriction is considered:

$$t_f \leq 1.2 \delta_f b.$$

Since for buckling the maximal normal stress $2\Delta\sigma$ has to be considered,

$$\epsilon = \sqrt{\frac{235}{2\Delta\sigma/\gamma_f}} \quad (12)$$

In the optimization procedure the unknown structural dimensions h , $t_w/2$, b and t_f are determined which minimize the cost K and fulfil the design constraints. The ranges of unknowns are taken as follows (in mm): $h = 500\text{--}1500$, $t_w/2 = 5\text{--}15$, $b = 300\text{--}1500$, $t_f = 5\text{--}25$.

The optimization procedure is carried out by using the software for the Feasible Sequential Quadratic Programming (FSQP) method developed by Zhou and Tits [28] and for Rosenbrock's hillclimb method. Rounded values are computed by a complementary special program [29]. The results of the optimization are given in Tables 3 and 4.

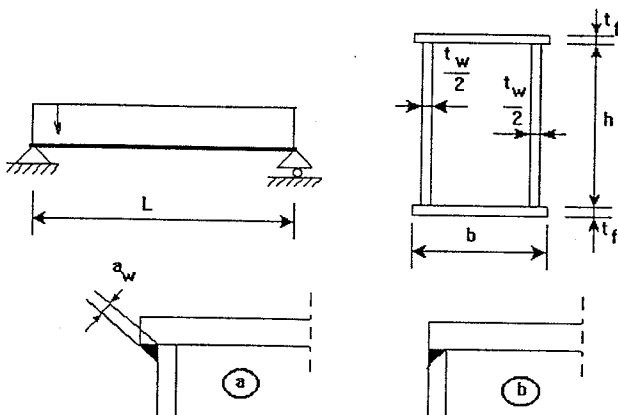

Fig. 3. Welded box beam (a) with fillet welds, (b) with 1/2 V butt welds

Table 3. Optimal versions of the box beam welded with fillet welds by various welding methods. Rounded values in mm

Welding method	k_f/k_m	h	$t_w/2$	b	t_f	A (mm ²)	K/k_m (kg)
SMAW	0.0	1270	9	725	15	44,610	7004
	0.5	1185	8	750	17	44,460	8063
	1.0	1125	8	765	18	45,540	9321
	1.5	1075	8	800	18	46,000	10,483
GMAW-C	0.0	1270	9	725	15	44,610	7004
	0.5	1230	9	750	16	46,140	7897
	1.0	1195	8	755	17	44,790	8242
	1.5	1175	8	750	17	44,300	8766
SAW	0.0	1195	9	690	15	42,210	6626
	0.5	1170	9	700	16	43,460	7349
	1.0	1145	9	685	17	43,900	7947
	1.5	1130	8	690	17	41,540	7991

Table 4. Optimal versions of the box beam welded with 1/2 V butt welds by various welding methods. Rounded values in mm

Welding method	k_f/k_m	h	$t_w/2$	b	t_f	A (mm ²)	K/k_m (kg)
SMAW	0.0	1265	9	730	15	44,670	7013
	0.5	1010	8	825	19	47,510	9715
	1.0	880	7	900	21	50,120	11,459
	1.5	810	6	960	22	51,960	12,340
GMAW-C	0.0	1265	9	730	15	44,670	7013
	0.5	1120	8	805	17	45,290	8219
	1.0	1040	7	810	19	45,340	8934
	1.5	965	7	850	20	47,510	10,201
SAW	0.0	1195	9	690	15	42,210	6627
	0.5	1095	9	700	17	43,510	7841
	1.0	1025	8	750	18	43,400	8514
	1.5	970	7	780	19	43,220	8910

It can be seen that the web thickness should be decreased when the fabrication cost factor increases, to decrease the weld size. If the web sizes decrease the flange sizes should be increased. This tendency is much stronger in the case of butt welds than that of fillet welds. The weight and total cost is larger for butt welds than for fillet welds. The cost savings achieved by using SAW instead of GMAW-C or SMAW in the case of $k_f/k_m = 1.5$ is about 11% and 26%, respectively. The advantage of SAW is that the fabrication cost is smaller and the fatigue stress range is larger since the welding can be carried out without stop/start positions.

4.2. Stiffened plate (Fig. 4)

Stiffened panels are widely used in bridge and ship structures, so it is of interest to study the minimum cost design of such structural elements. On the other hand, it has been shown [30] that the fabrication cost of a welded stiffened plate represents a significant part of the total cost.

The design rules of API [31] are used here for the formulation of the global buckling constraint for uniaxially compressed plate longitudinally stiffened by equally spaced uniform flat stiffeners of equal cross sections (Fig. 4). The cost function is defined according to Eq (7) in which $A = b_o t_f + \phi h_s t_s$; $\delta = 3$; $\kappa = \phi + 1$; $L_w = 2L\phi$; ϕ is the number of stiffeners.

The flat stiffeners are welded by double fillet welds, the size of

welds is taken as $a_w = 0.5 t_s$. The welding costs are calculated for SMAW, GMAW-C and SAW according to Table 2.

In the optimization procedure the given data are as follows. The modulus of elasticity for steel is $E = 2.1 \times 10^5$ MPa, the material density is $\rho = 7.85 \times 10^{-6}$ kg/mm³, Poisson's ratio is $\nu = 0.3$, the yield stress is $f_y = 235$ MPa, the plate width is $b_o = 4200$ mm, the length is $L = 4000$ mm. The axial compressive force is

$$N = f_y b_o t_{fmax} = 235 \times 4200 \times 20 = 1.974 \times 10^7 \text{ (N)}$$

The variables to be optimized are as follows (Fig. 4): the thickness of the base plate t_f , the sizes of stiffeners h_s and t_s and the number of stiffeners $\phi = b_o/a$.

The overall buckling constraint is given by

$$N \leq \chi f_y A \tag{14}$$

where the buckling factor χ is given in function of the reduced slenderness $\bar{\lambda}$

$$\chi = 1 \quad \text{for} \quad \bar{\lambda} \leq 0.5 \tag{15a}$$

$$\chi = 1.5 - \bar{\lambda} \quad \text{for} \quad 0.5 \leq \bar{\lambda} \leq 1 \tag{15b}$$

$$\chi = 0.5/\bar{\lambda} \quad \text{for} \quad \bar{\lambda} \geq 1 \tag{15c}$$

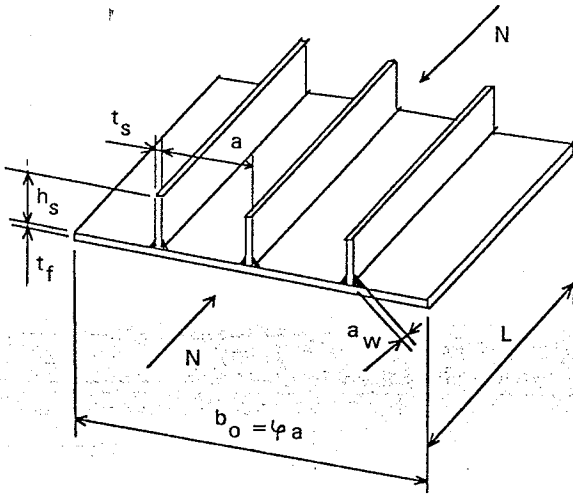

Fig. 4. Uniaxially compressed longitudinally stiffened plate

where

$$\bar{\lambda} = \frac{b_0}{t_f} \sqrt{\frac{12(1-\nu^2)f_y}{E\pi^2k}} \quad (16)$$

$$k = \min(k_R, k_F); \quad k_R = 4\phi^2 \quad (17a,b)$$

$$k_F = \frac{(1+\alpha^2) + \phi\gamma}{\alpha^2(1+\phi\delta_p)} \quad \text{when } \alpha = \frac{L}{b_0} \leq 4\sqrt{1+\phi\gamma} \quad (17c)$$

$$k_F = \frac{2(1+\sqrt{1+\phi\gamma})}{1+\phi\gamma} \quad \text{when } \alpha \geq 4\sqrt{1+\phi\gamma} \quad (17d)$$

$$\delta_p = \frac{h_s t_s}{b_0 t_f}; \quad \gamma = \frac{EI_s}{b_0 D}; \quad I_s = \frac{h_s^3 t_s}{3}; \quad D = \frac{Et_f^3}{12(1-\nu^2)} \quad (17e)$$

so

$$\gamma = 4(1-\nu^2) \frac{h_s^3 t_s}{b_0 t_f^3} = 3.64 \frac{h_s^3 t_s}{b_0 t_f^3} \quad (17f)$$

I_s is the moment of inertia of one stiffener about an axis parallel to the plate surface at the base of the stiffener, D is the flexural stiffness of the base plate.

The constraint on local buckling of a flat stiffener is defined by means of the limiting slenderness ratio according to Eurocode 3 [27].

$$\frac{h_s}{t_s} \leq \frac{1}{\beta_s} = 14 \sqrt{\frac{235}{f_y}} \quad (18)$$

The optimization procedure is carried out by using the same software as mentioned in Section 4.1. The ranges of unknowns are taken as follows (in mm): $t_f = 6-20$, $h_s = 84-280$, $t_s = 6-25$, $\phi = 4-15$.

The computational results are summarized in Table 5.

It can be seen that the minimum weight design ($k_f = 0$) results in many more stiffeners than the minimum cost design. The optimal plate dimensions depend on cost factors k_f/k_m and C_2 , so the results illustrate the effect of the welding technology on the structure and costs.

It should be noted that, in the case of SMAW, the ϕ_{opt} values are very sensitive to k_f/k_m , so in Table 5 more k_f/k_m values are treated.

For $k_f/k_m = 1.5$ the cost savings achieved by using SAW instead of SMAW or GMAW-C are $100(9330-5530)/9330 = 41\%$ and $100(6220-5530)/6220 = 11\%$.

In the case of SMAW and $k_f/k_m = 1.5$ the material cost component is $\rho LA = 103260 \times 7.85 \times 10^{-6} \times 4 \times 10^3 = 3242$ kg, so the fabri-

Table 5. Optimal rounded sizes of a uniaxially compressed longitudinally stiffened plate, double fillet welds carried out by different welding methods, dimensions in mm

Welding method	k_f/k_m	t_f	h_s	t_s	ϕ	A (mm ²)	K/k_m (kg)
SMAW	0.00	10	200	15	15	87,000	2732
	0.10	13	210	17	11	91,560	3516
	0.18	15	220	16	9	94,680	3929
	0.20	16	220	16	8	95,360	3945
	0.50	19	230	17	6	103,260	5272
	1.00	19	230	17	6	103,260	7301
	1.50	19	230	17	6	103,260	9330
GMAW-C	0.0	10	200	15	15	87,000	2732
	0.3	15	215	16	9	93,960	3716
	0.5	16	220	16	8	95,360	4146
	1.0	19	230	17	6	103,260	5227
	1.5	19	230	17	6	103,260	6220
SAW	0.0	10	200	15	15	87,000	2732
	0.5	15	220	16	9	94,680	3944
	1.0	19	230	17	6	103,260	4767
	1.5	19	230	17	6	103,260	5530

cation cost represents $(100(9330-3242)/9330 = 65\%$ of the whole cost, this significant part of costs affects the dimensions and the economy of stiffened plates.

5. Conclusions

- (a) Cost functions are formulated by means of the COSTCOMP software for longitudinal fillet and 1/2 V butt welds carried out with the manual SMAW, semi-automatic GMAW-C and automatic SAW methods in downhand position.
- (b) Using these cost functions the optimal dimensions of a box beam and a stiffened plate are computed which minimise the total cost and fulfil the design constraints.
- (c) The comparison of optimal solutions shows that significant cost savings may be achieved by using SAW instead of SMAW or GMAW-C. The saving is larger for a stiffened plate since the ratio K_p/K is much larger for a stiffened plate than that for a box beam.
- (d) Numerical computations show that the optimal dimensions of a box beam or a stiffened plate depend on the applied welding method and illustrate the necessity of cooperation between designers and fabricators.
- (e) The automatic welding methods are advantageous not only for welding time reduction but also for higher fatigue design stress, corresponding to detailed category for welds worked out without stop/start positions.
- (f) Comparison of optimal solutions for minimum weight ($k_p/k_m = 0$) and minimum cost shows that the fabrication cost affects significantly the optimal dimensions, therefore the consideration of the total cost function results in more economic structural versions.
- (g) Comparison of results for fillet and 1/2 V butt welds shows that box beams with fillet welds are more economic than those with 1/2 V butt welds.
- (h) The weight and cost savings achieved by automatic welding depend on the ratio K_p/K . For structures in which the fabrication cost is higher compared to the whole cost, e.g. in stiffened plates, the effect of automatization is higher. For stiffened plates the ratio K_p/K is about 65%, for the box beams calculated in our example this ratio is about 18%.

Acknowledgements

The authors would like to thank Andre L. Tits and Jian L. Zhou University of Maryland for the opportunity of using the CFSQP algorithm. This work received support from the Hungarian Fund for Scientific Research Grants OTKA T-4479 and T-4407 and from the Ministry of Culture and Education under grant No. 474/1992.

References

1. J. Farkas: *Optimum Design of Metal Structures*. Akadémiai Kiadó, Budapest, Ellis Horwood, Chichester, 1984.
2. A. Firkins, D. Hemphill: Fabrication cost of structural steel-work. *Steel Construction (Australia)*, Vol. 24, No. 2, pp. 2-14, 1990.
3. J. Farkas: Minimum cost design of tubular trusses considering buckling and fatigue constraints. In *Tubular Structures*, 3rd Int. Symposium, 1989, Lappeenranta, pp. 451-459. E. Niemi, P. Mäkeläinen (eds), Elsevier, London, 1990.
4. J. Farkas: Techno-economic considerations in the optimum design of welded structures. *Welding in the World*, Vol. 29, No. 9/10, pp. 295-300, 1991.
5. J. Farkas: Cost comparisons of plates stiffened on one side and cellular plates. *Welding in the World*, Vol. 30, No. 5/6, pp. 132-137, 1992.
6. G. Pahl, K. H. Beelich: Kostenwachstumsgesetze nach Ähnlichkeitsbeziehungen für Schweissverbindungen. *VDI-Bericht*, Nr. 457, pp. 129-141, Düsseldorf, 1992.
7. COSTCOMP, Programm zur Berechnung der Schweisskosten. Deutscher Verlag für Schweissttechnik, Düsseldorf, 1990.
8. H.J.M. Bodt: *The Global Approach to Welding Costs*. The Netherlands Institute of Welding, The Hague, 1990.
9. J. Farkas: Minimum cost design of welded structures. In *Engineering Design in Welded Constructions*, Proceedings of the Int. Conference IIW, Madrid, Spain, pp. 135-142. Pergamon Press, Oxford, 1992.
10. J.A. Donnelly: Determining the cost of welded joints. *Engineering J.* (Amer. Inst. Steel Construction), Vol. 5, pp. 146-147, 1968.
11. Y.M. Likhtarnikov: *Metal Structures*. Stroyizdat, Moscow, 1968 (in Russian).
12. G. Aichele: *Kalkulation und Wirtschaftlichkeit in der Schweissttechnik (Calculation and economy in the welding technology)*. Deutscher Verlag für Schweissttechnik, Düsseldorf, 1985.
13. R.L. Peurifoy: *Estimating Construction Costs*, 3rd edn. McGraw Hill, New York, 1975.
14. V.V. Volkov: Determining fabrication times for structural parts of industrial buildings. *Trudy TsNII Proektstalkonstruksiya*, Vyp. 23, pp. 34-45, 1978 (in Russian).
15. R.B.G. Yeo: Cost effective steel fabrication. Part 2. Design for welding. *Metal Construction*, Vol. 15, No. 3, pp. 151-156, 158, 1983.
16. I.E. Winkle, D. Baird: Towards more effective structural design through synthesis and optimisation of relative fabrication costs. *Trans. Royal Inst. Naval Archit. RINA*, No. 128, pp. 313-336, 1986.
17. P. Drews, G. Starke: Robot welding systems. In *Advanced Joining Technologies*, Proc. Int. Inst. of Welding Congress on Joining Research, pp. 83-91. Chapman and Hall, London, 1990.
18. K. Horikawa *et al.*: The present position in the practical application of arc welding robots and proposals on joint design for robot welding of steel structures. *Welding in the World*, Vol. 30, No. 9/10, pp. 256-274, 1992.
19. D.T. Fern, R.B.G. Yeo: Designing cost effective weldments. In *Welded Structures '90*. Int. Conference, London, 1990, pp. 149-158. Welding Inst., Abington Publ. 1990.

20. D.W. Chalmers: Structural design for minimum cost. In *Advances in Marine Structures*. Proc. Int. Conference, Dunfermline, pp. 650–669. Elsevier, London, 1986.
21. B. Forde, Y. Ch. Leung, S.F. Stierner: Computer-aided design evaluation of steel structures. Proc. IABSE Congress, pp. 421–428. Vancouver, 1984.
22. P. Sen, W.B. Shi, J.B. Caldwell: Efficient design of panel structures by a general multiple criteria utility. *Engineering Optimization*, Vol. 14, pp. 287–310, 1989.
23. V. Malin: Designer's guide to effective welding automation. Part 1–2. *Welding Journal*, Vol. 64, pp. 17–29, Nov. 1985, Vol. 65, pp. 43–52, June 1986.
24. P.T. Pedersen, N.-J.R. Nielsen: Structural optimization of ship structures. In *Computer Aided Optimal Design: Structural and Mechanical Systems*, Proc. NATO Advanced Study Inst., Troia, pp. 921–941. Portugal, Springer, Berlin, 1986.
25. J.C. Ramirez, A. Touran: An integrated computer system for estimating welding cost. *Cost Engineering*, Vol. 33, No. 8, pp. 7–14, 1991.
26. H.H. Ott, V. Hubka: Vorausberechnung der Herstellkosten von Schweisskonstruktionen (Fabrication cost calculation of welded structures). *Proc. Int. Conference on Engineering Design ICED*, 1985, Hamburg, pp. 478–487. Heurista, Zürich, 1985.
27. Eurocode 3. Design of steel structures, Part 1.1, CEN, European Committee for Standardization, Brussels, 1992.
28. J.L. Zhou, A. Tits: User's guide for FSQP Version 3.0. Systems Research Center, University of Maryland, Tech. Rep. SRC-TR-90-60r1f, College Park, MD 20742, 1992.
29. K. Jármai: Single- and multicriteria optimization as a tool of decision support system. *Computers in Industry*, Vol. 11, pp. 249–266, 1989.
30. J. Farkas, K. Jármai: Minimum cost design of laterally loaded welded rectangular cellular plates. In *Structural Optimization '93 World Congress*, Rio de Janeiro. Proc. Vol. 1, pp. 205–212, 1993.
31. American Petroleum Institute: API Bulletin on Design of flat plate structures. Bul. 2V, 1st edn, 1987.