

Jármai,K., Farkas,J., Uys,P.: Optimum design and cost calculation of a simple frame with welded or bolted corner joints, *56th Annual Assembly of International Institute of Welding, July 6-10, 2003, Bucharest, IIW-Doc. XV-1145-03, XV-WG9-24-03, 16 p.*

Optimum design and cost calculation of a simple frame with welded or bolted corner joints

Jármai,K.¹, Farkas,J.¹, Uys,P.²

¹University of Miskolc, Hungary, ²University of Pretoria, South Africa

Abstract

A one bay one storey steel planar frame is constructed from rolled I-profile elements consisting of universal columns and a universal beam. The buckling strengths of the columns and beam according to Eurocode 3 (2002) constitute the design constraints. The beam and column profiles are optimised to minimize the structural mass subject to the design constraints for both a flush-end-plate bolted (semi-rigid) structure and a welded (rigid) structure. For the specific numerical case considered the structure is subject to a horizontal force and a uniformly distributed vertical load. Comparing the costs of these optimal solutions, shows that the bolted frame is 7% or 14% cheaper than the welded frame on the base of British and South African cost data respectively.

IIW-Thesaurus keywords:

welded structures, frames, semi-rigid joints, bolted connections, cost calculation, frame stability

1. Introduction

Steel frames can be constructed using either welded or bolted connections. Welded joints are rigid, while the behaviour of bolted joints is semi-rigid, since the local displacements of joint components cause an additional angle deformation of corner connections. The rigidity of a beam-to-column frame connection is characterized by the diagram bending moment versus angle deformation as given in [1]. According to [2] welded connections generally fulfil the requirements for rigid rotational stiffness.

The additional rotations affect the bending moments, normal and shear forces in frame members and the frame stability. Thus, this effect should be taken into account in the frame optimization as well.

In a previous study [3, 4] the cost differences between welded and bolted beam-to-column connections were shown and also how the economics of structures are influenced by the differences in bending moments and shear forces. The aim of the present study is to investigate these differences in the case of a simple planar sway frame and also to determine the optimum design of the frame in the case of welded as well as bolted connections. This is a relevant issue since single story sway frames constitute the basic buildings units of structures such as warehouses, portal cranes, supporting frames for pressure vessels, vehicle structures.

The optimum design of frames with semi-rigid joints has been dealt with by several authors e.g. Al-Salloum & Almusallam [5], Simões [6], Kameshki & Saka [7]. The difficulty of the optimization is that the additional angle deformation depends on many parameters (such as the type of bolted connection, elongation of bolts and local displacements of plate elements of connected profiles). Thus, the bending moments depend on unknown profile dimensions. To ease the optimization procedure the guess formula for the joint stiffness proposed by Steenhuis et al.[8] is used here.

Another problem is that available rolled I-section rods have to be used. These present a discrete range of profiles which are listed by manufacturers in tabulated form, e.g. universal beams (UB) and columns (UC) (as given by ARBED catalogue of structural shapes [9]). The characteristics of these profiles (cross-sectional area, moments of inertia etc.) depend on main section dimensions and it is difficult to calculate them as simple functions, which is required for optimization purposes. For this reason approximate functions determined by curve-fitting selection using only one variable (profile height) are used.

The optimization of a welded as well as a bolted frame is performed using the structural volume as objective function to be minimized, and the costs are calculated and compared to each other. British and South-African cost data are used.

2. Forces and bending moments in the frame

We investigate a one-storey one-bay sway (unbraced) frame shown in Figure 1. loaded by a uniformly distributed vertical load of intensity p and a concentrated horizontal force F . The corner bending moment M_p (Fig.2) is derived from an angle deformation equation as follows.

The angle deformation of the beam due to load p (Fig.3) is

$$\varphi_0 = \frac{pL^3}{24EI_2}, \quad (1)$$

and due to the bending moments

$$\varphi_1 = \frac{M_p L}{2EI_2}, \quad (2)$$

where E is the elastic modulus and I_2 is the moment of inertia of the beam section. The angle deformation of the column end due to the bending moment M_p and reactive force $N_{p2} = 3M_p/(2H)$ is

$$\varphi_2 = \frac{M_p H}{4EI_1}, \quad (3)$$

where I_1 is the moment of inertia of the column section. The angle deformation equation, considering the angle difference caused by the semi-rigid connection of stiffness S_j , is

$$\varphi_0 - \varphi_1 - \varphi_2 = \theta = \frac{M_p}{S_j}. \quad (4)$$

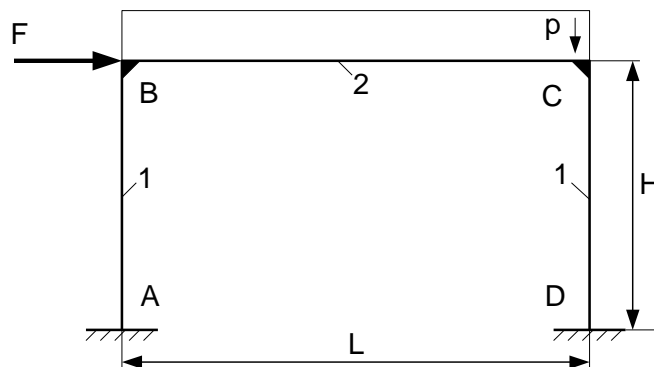

Figure 1. Unbraced planar frame

From Eq.(4) one obtains

$$M_p = \frac{pL^2}{24} \cdot \frac{1}{\frac{1}{2} + \frac{HI_2}{4LI_1} + \frac{EI_2}{LS_j}} \quad (5)$$

Note that for welded (rigid) joints $S_j \rightarrow \infty$ and the third member in the denominator becomes zero.

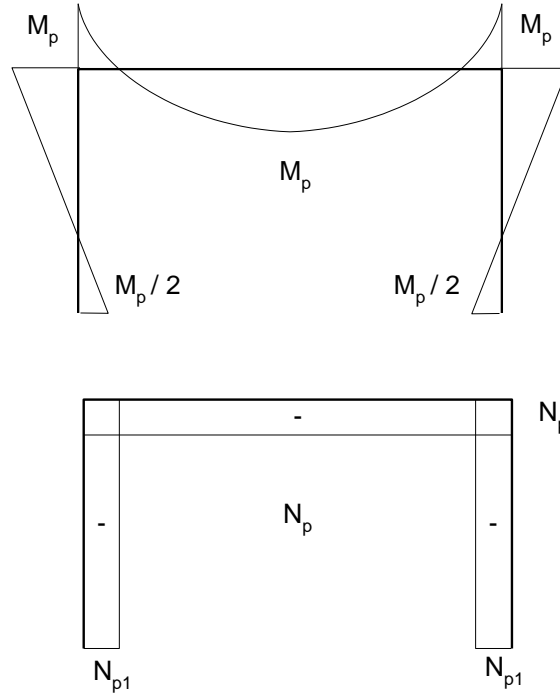

Figure 2. Diagrams of bending moments and axial forces

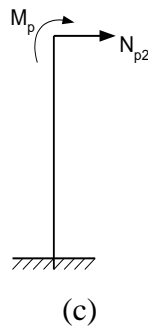
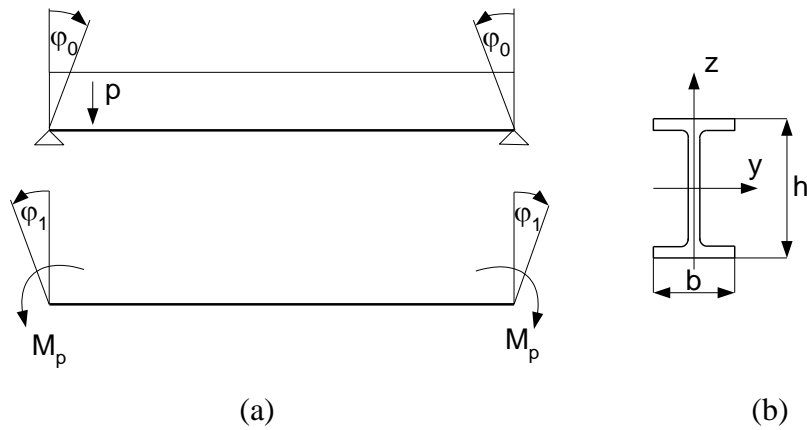

Figure 3. (a) Angle deformations of the beam due to uniform normal load. (b) The main dimensions of a rolled I-beam. (c) Bending moment and horizontal force acting on a column

Similarly, the corner bending moments due to the horizontal force F (Fig.4) can be calculated considering the following angle deformation in the beam due to M_F (Fig.5):

$$\varphi_{MF} = \frac{M_F L}{6EI_2}, \quad (6)$$

and the angle deformations of the column top due to $F/2$ and M_F are

$$\frac{FH^2}{4EI_1} - \frac{M_F H}{EI_1}, \quad (7)$$

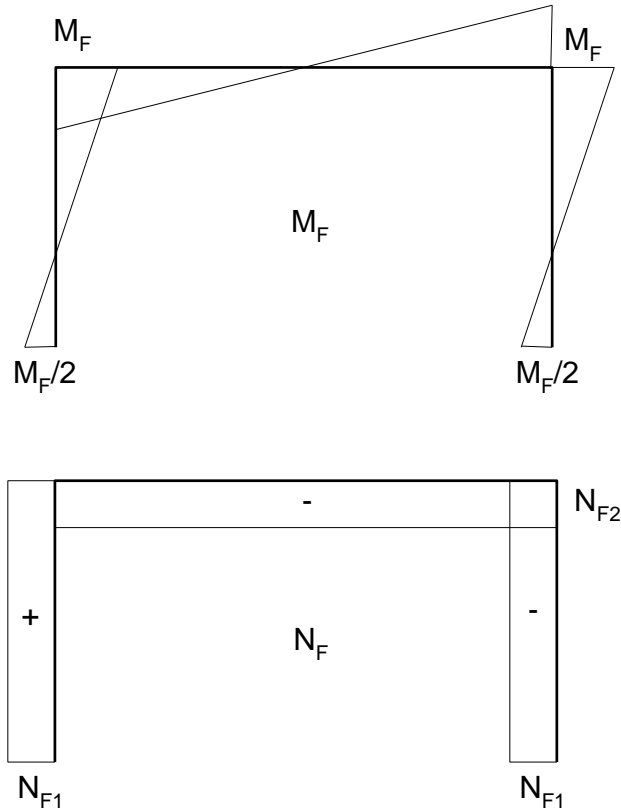

Figure 4. Bending moments and axial forces due to the horizontal force F

Considering also the angle difference caused by semi-rigid joints, the angle equation can be expressed as

$$\frac{FH^2}{4EI_1} - \frac{M_F H}{EI_1} = \frac{M_F L}{6EI_2} + \frac{M_F}{S_j}. \quad (8)$$

From Eq. (8) it follows that

$$M_F = \frac{FH}{4} \cdot \frac{1}{1 + \frac{LI_1}{6HI_2} + \frac{EI_1}{HS_j}}. \quad (9)$$

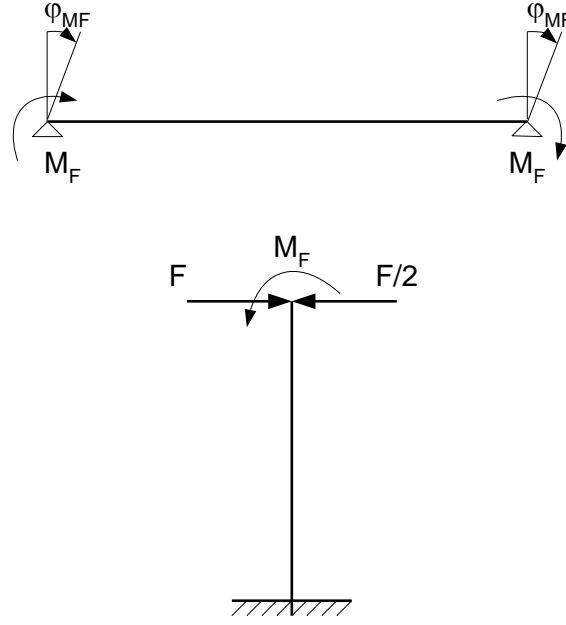

Figure 5. Angle deformations of the beam due to horizontal force F . Bending moment and horizontal forces acting on the columns in the case of the horizontal load F

3. Design constraints

The columns and the beam are loaded by bending and an axial force. Since rolled I-section rods are used, these should fulfil the constraints on combined bending and compression to avoid overall flexural and torsional buckling as well as lateral-torsional buckling. These stress constraints are formulated according to Eurocode 3 (2002) (EC3) [10].

3.1 Bending and axial compression constraint of the column CD

The buckling constraint about the y -axis (Fig.3) requires that:

$$\frac{N_1}{\chi_{y1} f_{y1} A_1} + k_{yy1} \frac{M_C}{\chi_{LT1} f_{y1} W_{y1}} \leq 1, \quad (10)$$

and for buckling about z -axis

$$\frac{N_1}{\chi_{z1} f_{y1} A_1} + k_{zy1} \frac{M_C}{\chi_{LT1} f_{y1} W_{y1}} \leq 1, \quad (11)$$

where $f_{y1} = f_y / \gamma_{M1}$; $\gamma_{M1} = 1.1$, f_y is the yield stress, γ_{M1} is the partial safety factor.

The compression force is

$$N_1 = \frac{pL}{2} + \frac{2M_F}{L}, \quad (12)$$

and the bending moment is calculated as

$$M_C = M_p + M_F. \quad (13)$$

The overall buckling factor for the y-axis is

$$\chi_{y1} = \frac{1}{\phi_{y1} + \sqrt{\phi_{y1}^2 - \bar{\lambda}_{y1}^2}}, \quad (14)$$

where

$$\phi_{y1} = 0.5[1 + \alpha_{y1}(\bar{\lambda}_{y1} - 0.2) + \bar{\lambda}_{y1}^2], \quad (15)$$

$$\alpha_{y1} = 0.21 \quad \text{if} \quad h_1/b_1 > 1.2,$$

$$\alpha_{y1} = 0.34 \quad \text{if} \quad h_1/b_1 \leq 1.2, \quad (16)$$

and

$$\bar{\lambda}_{y1} = \frac{K_1 H}{r_{y1} \lambda_E}; K_1 = 2; r_{y1} = \sqrt{\frac{I_{y1}}{A_1}}; \lambda_E = \pi \sqrt{\frac{E}{f_y}}. \quad (17)$$

According to Steenhuis et al. [8] the joint stiffness for a bolted joint with a flush end plate and cover plate (Fig.6) can be approximated by the following formula

$$S_j = \frac{Ez^2 t_{fc}}{11.5}, \quad (18)$$

where t_{fc} is the column flange thickness and z is the arm of the bending forces in the joint, which is approximately equal to the web height, $z = 0.55h_2$.

Furthermore

$$k_{yy1} = 0.9 \left(1 + 0.6 \bar{\lambda}_{y1} \frac{N_1}{\chi_{y1} f_{y1} A_1} \right) \leq 0.9 \left(1 + 0.6 \frac{N_1}{\chi_{y1} f_{y1} A_1} \right). \quad (19)$$

where k_{yy1} parameter considers the secondary effects, the interaction between compression and bending.

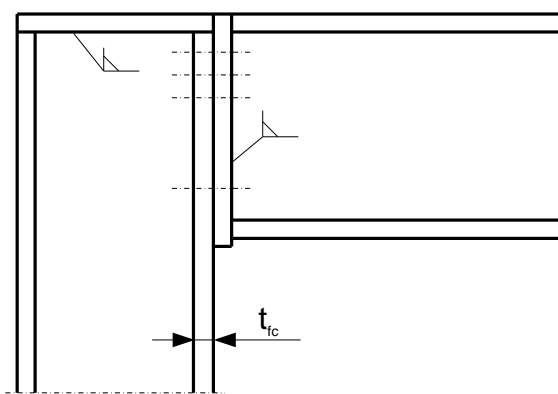

Figure 6. Bolted connection with flush-end plate

The lateral-torsional buckling factor is

$$\chi_{LT1} = \frac{1}{\phi_{LT1} + \sqrt{\phi_{LT1}^2 - \bar{\lambda}_{LT1}^2}}, \quad (20)$$

with

$$\phi_{LT1} = 0.5[1 + \alpha_{LT1}(\bar{\lambda}_{LT1} - 0.2) + \bar{\lambda}_{LT1}^2], \quad (21)$$

$$\bar{\lambda}_{LT1} = \sqrt{\frac{W_{y1} f_y}{M_{cr1}}} \quad (22)$$

$$M_{cr1} = 1.132\pi^2 E \frac{I_{z1}}{H} \sqrt{\frac{I_{\omega 1}}{I_{z1}} + \frac{H^2 GI_{t1}}{\pi^2 EI_{z1}}} \quad (23)$$

$$\alpha_{LT1} = 0.34 \quad \text{if} \quad h_1 / b_1 \leq 2$$

$$\alpha_{LT1} = 0.49 \quad \text{if} \quad h_1 / b_1 > 2 \quad (24)$$

The overall buckling factor for z-axis is

$$\chi_{z1} = \frac{1}{\phi_{z1} + \sqrt{\phi_{z1}^2 - \bar{\lambda}_{z1}^2}} \quad (25)$$

$$\phi_{z1} = 0.5[1 + \alpha_{z1}(\bar{\lambda}_{z1} - 0.2) + \bar{\lambda}_{z1}^2] \quad (26)$$

$$\bar{\lambda}_{z1} = \frac{K_1 H}{r_{z1} \lambda_E}; K_1 = 2; r_{z1} = \sqrt{\frac{I_{z1}}{A_1}} \quad (27)$$

$$\alpha_{z1} = 0.34 \quad \text{if} \quad h_1 / b_1 > 1.2$$

$$\alpha_{z1} = 0.49 \quad \text{if} \quad h_1 / b_1 \leq 1.2 \quad (28)$$

$$k_{zy} = 1 - \frac{0.05 \bar{\lambda}_{z1}}{C_{mLT1} - 0.25} \cdot \frac{N_1}{\chi_{z1} f_{y1} A_1} \geq 1 - \frac{0.05}{C_{mLT1} - 0.25} \cdot \frac{N_1}{\chi_{z1} f_{y1} A_1} \quad (29)$$

$$C_{mLT1} = C_{my1}^2 \frac{a_{LT1}}{\sqrt{\left(1 - \frac{N_1}{\chi_{z1} f_{y1} A_1}\right) \left(1 - \frac{N_1}{N_{crT1}}\right)}} \quad (30)$$

$$C_{my1} = C_{my.01} + (1 - C_{my.01}) \frac{\sqrt{\varepsilon_y} a_{LT1}}{1 + \sqrt{\varepsilon_y} a_{LT1}} \quad (31)$$

$$\varepsilon_y = \frac{M_C A_1}{W_{y1} N_1}; \quad a_{LT1} = 1 - \frac{I_{t1}}{I_{y1}} \quad (32)$$

$$C_{my.01} = 0.79 + 0.21\psi_1 + 0.36(\psi_1 - 0.33) \frac{N_1}{\chi_{z1} f_{y1} A_1}; \quad \psi_1 = -0.5 \quad (33)$$

The elastic torsional-flexural buckling force is

$$N_{crT1} = \frac{1}{r_{y1}^2 + r_{z1}^2} \left(GI_{t1} + \frac{\pi^2 EI_{\omega 1}}{H^2} \right) \quad (34)$$

and the corresponding reduced slenderness is

$$\bar{\lambda}_{T1} = \sqrt{\frac{A_1 f_y}{N_{crT1}}} \quad (35)$$

For the calculation of Eq.(27) the maximum value from $\bar{\lambda}_{z1}$ and $\bar{\lambda}_{T1}$ should be used.

3.2 Bending and axial compression of the beam BC

Similarly to Eqs (10) and (11) the stress constraints are as follows

$$\frac{N_2}{\chi_{y2} f_{y1} A_2} + k_{yy2} \frac{M_C}{\chi_{LT2} f_{y1} W_{y2}} \leq 1 \quad (36)$$

and

$$\frac{N_2}{\chi_{z2} f_{y1} A_2} + k_{zy2} \frac{M_C}{\chi_{LT2} f_{y1} W_{y2}} \leq 1 \quad (37)$$

The other formulae are similar to those given in Section 3.1, but with subscript 2 except the following:

$$K_2 = 1.3 \quad (38)$$

and

$$N_2 = \frac{F}{2} + \frac{3M_p}{2H} \quad (39)$$

$$C_{my,02} = 1 + \left(\frac{\pi^2 EI_{y2} \delta_{x2}}{L^2 M_C} - 1 \right) \frac{N_2}{\chi_{y2} f_{y1} A_2} \quad (40)$$

$$\delta_{x2} = \frac{5pL^4}{384EI_{y2}} - \frac{M_p L^2}{8EI_{y2}} \quad (41)$$

In the above formulae the following geometric section characteristics should be calculated:

A - cross-sectional area

I_y, I_z - moments of inertia about y and z axis, respectively

W_y - section modulus about y axis

r_y and r_z - radii of gyration about y and z axis, respectively

I_t - torsional constant

I_{ω} - warping constant

and values of t_{fc} and z should be given (Eq. 18).

These values are given in tabulated form for available UB and UC series produced by ARBED [9]. To ease the calculations, we have used approximate functions expressing the above characteristics in the function of section height h . To illustrate these approximate functions, the selected UB profiles are given in Table 1 with their heights and cross-sectional areas. These cross-sectional areas can be approximated by the following curve-fitting function

$$A = -489.58486 + 14.366815h + 0.01824055h^2 \quad (A \text{ in mm}^2, h \text{ in mm}) \quad (42)$$

For instance, for UB 305x165x46.1 with $h = 306.6$ mm Eq.(41) gives $A = 5629.96$ mm² instead of the actual value of 5875 mm².

Table 1. Heights and cross-sectional areas of selected UB profiles according to ARBED [9]

UB profile	h (mm)	A (mm ²)
152x89x16	152.4	2032
178x102x19	177.8	2426
203z133x25	203.2	3197
254x146x31	251.4	3968
254x146x37	256.0	4717
305x165x46.1	306.6	5875
356x171x57	358.0	7256
406x178x74	409.4	8554
457x191x74	457.0	9463
457x191x82	460.0	10450
610x229x113	607.6	14390
686x254x140	683.5	17840
838x292x194	840.7	24680

4. Optimization characteristics and results

The objective function to be minimized is the structural volume

$$V = 2A_1H + A_2L \quad (43)$$

The design constraints are described in Section 3. The unknown variables are the heights of column and beam rolled I-sections h_1 and h_2 .

The Rosenbrock hillclimb algorithm [11] has been applied to find the optimum column and beam profiles, which minimize the volume (weight) and fulfil the design constraints.

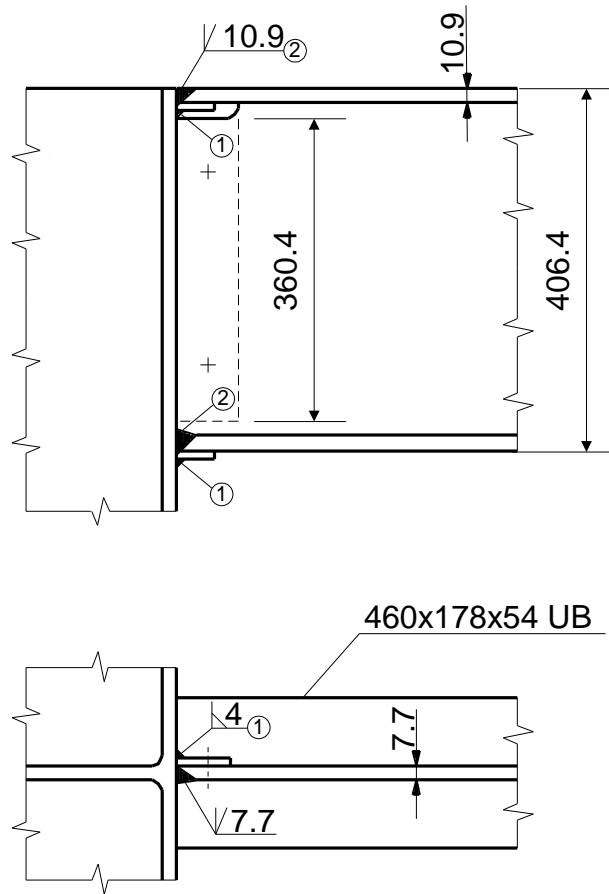

Figure 7. The fully welded connection

5. Cost calculation for frames with welded and bolted joints

5.1 British cost data

The optimum design results in the following optimal British profiles:

Bolted version: columns UC203x203x52
 beam UB406x178x54

Welded version: columns UC203x203x86
 beam UB406x178x54

The moment capacity of the bolted connection is 162 kNm [12], while the calculated bending moment in corner C is 76 kNm.

Costs of the frame with bolted connections:

Material cost: UB 406x178x54 21 £/m = 30.0 \$/m, length L = 7.62 m, 228.6 \$

UC 203x203x52 20 £/m = 28.6 \$/m, length 2H= 7.32 m..... 209.4 \$

Material cost of bolts (100 bolts cost is 32.- £) 16 bolts 0.32x16 = 5 £ = 7.3 \$

Total material cost 445.3 \$

Manufacturing costs: cutting of the beam ends (main) 25 Ł = 35.8 \$

Preparation (assembly) cost is calculated similarly than in the case of welded joint, with the same formula as follows

$$K_{F1} = k_F \Theta \sqrt{\kappa \rho V} = 0.6 \times 2 \sqrt{3 \times 792.8} = 58.5 \$$$

since the total mass is $54.1 \times 7.62 + 52 \times 7.32 = 792.8 \text{ kg}$

The cost of the bolted connection of medium type (endplate 25 mm thick, 200 mm wide, 410 mm deep, holing, welding to the end plate with fillet welds of leg size min 6 max 12 mm around the profile)

$$87 \text{ Ł} = 124.4 \$$$

total manufacturing costs 218.7 \$

Material and fabrication together 664.- \$

Costs of the frame with welded connections:

Material cost: UB 406x178x54 21 Ł/m = 30.0 \$/m, L = 7.62 m,228.6 \$

UC 203x203x86 32 Ł/m = 45.8 \$/m. 2H= 7.32 m335.0 \$

Manufacturing costs: cutting of the beam ends (main) 25 Ł = 35.8 \$

$$\text{Welding } K_w = k_F \left(\Theta_d \sqrt{\kappa \rho V} + 1.3 \sum_i \alpha_{pi} C_{wi} a_{wi}^n L_{wi} \right)$$

$$\rho V = 7.62 \times 54.1 + 2 \times 3.66 \times 86.1 = 1042.5 \text{ kg/m}$$

parts of the second member:

$$\text{flanges } 1.3 \times 0.5214 \times 10^{-3} \times 10.9^2 \times 2 \times 177.7 = 28.6 \text{ min}$$

$$\text{web } 1.3 \times 2 \times 0.5214 \times 10^{-3} \times 7.7^2 \times 360.4 = 14.5 \text{ min}$$

$$\text{flange backing } 1.3 \times 3 \times 0.7889 \times 10^{-3} \times 4^2 \times 2 \times 177.7 = 17.5 \text{ min}$$

$$\text{web backing } 1.3 \times 2 \times 0.7889 \times 10^{-3} \times 4^2 \times 360.4 = 11.8 \text{ min}$$

Total 72.4 min

$$K_w = 0.6 \left(2 \sqrt{3 \times 1042.5} + 72.4 \right) = 110.5 \$$$

Total manufacturing cost 146.3 \$

Material and manufacturing together 709.9 \$.

5.2 South African cost data

Tables 2-4 show the details of the cost calculation.

Table 2. South African cost data

Item	Units	Rand value	Dollar value	Reference
UB 406 x 178 x 54	R/m	303,56	23,35	Alert Steel [13]
UC 203 x 203 x 52	R/m	298.1	22.9	Alert Steel
UC 203 x 203 x 86	R/m	493.6	37.9	Alert Steel
Plate 2.5 x 1.2 x 20	R	2533.5	194.9	Alert Steel
Flat bar for back strips 40 x 5	R/m	8.0	0.6	Alert Steel
Total Overhead, Labour,	R/h	180	22.5	Spencer [14]
Consumables & Power				
Cost of cutting plates :		1.08	0.08	Alert steel
Material cost				
Drilling of M20 holes	R/hole	5	0.38	Jan Brand UP [15]
8.8 grade M20bolts	R each	6.97	0.54	Screw Man [16]
Cost of cutting R180/h, 0.17min/25mm	R/mm	0.0204		

Table 3. Calculation of costs (R = Rand) for rigid structure

Item	R/m	M	R	R	\$
Price					
UB406x178x54	303.6	7.62	2313.1		
UC203x203x86	493.6	7.32	3613.2		
Str40x5 flanges	8.0	0.7	5.7		
Str40x5 webs	8.0	0.7	5.8		
Total			5937.8	5938	742.2
Mass					
	Kg/m	M	Kg	min	
UB	54.1	7.62	412.2		
UC	86.1	7.32	630.3		
Total			1042.5		
Assembly & tacking time				111.8	
Welding time					
	α_p	C_w	a_w^2	L	min
flanges	1	0.000521	118.8	2x177.7	28.6
webs	2	0.000521	57.8	2x360.4	14.5
flange strips	3	0.000789	16	2x177.7	17.5
Web strips	2	0.000789	16	2x360.4	11.8
Total					72.4
Total welding cost				R	532.9 66.6
Cutting					
	length	min	R/min	R	
UB	402.6	2.7	3	8.2	
UC	444.6	3.0	3	9.1	
Total cutting				17.3	
Total manufacturing cost					550.2 68.8
Total manufacturing and material					6488.2 810.9

Table 4. Calculation of cost for semi-rigid structure

Item	R/m	m	R	R	\$
Bolts	7.0	16	111,5		
UB406X178X54	303.6	7,6	2313,1		
UC203X203X52	298.1	7,3	2182,2		
Plates 200X25	254.5	0,8	208,7		
Total material			4815,6	4843.5	605.4
Manufacturing					
	Mm	min/mm	R/min	R	
Cutting					
Plate	400	0,0068	3	8.2	
Beam	402.6	0,0068	3	8.2	
Columns	412.4	0,0068	3	8.4	
Total cutting				24.8	
Assembly & Tacking					
	kg/m	m	kg	min	
UB	54.1	7.6	412.2		
End plates	39.2	0.8	32.1		
Total			444.4	73.0	
Welding					
	α_p	C_w	a_w^2	L	min
Flanges to plate	1	0.000789	36.0	4x177.7	26.3
Webs to plate	2	0.000789	36.0	2x360.4	53.3
Total welding cost					238.4 29.8
Drilling					
	R/hole	nr. Holes		R	
	5	16		80	10
Assembly & bolting time					
UC	52	7.3	380.6		
UB	54.1	7.6	412.2		
End plates	39.2	0.8	32.1		
Total			825.0	99.5	
Assembly & bolting cost				196.3	24.5
Total manufacturing				514.4	64.3
Total for bolted connection				5277.8	669.7

Conclusion

The detailed cost calculations show that according to British data, the bolted connection is 7% cheaper than the welded one. This difference has two components: the difference between material costs and the difference between fabrication costs.

According to the South African data, the bolted connection is about 14% cheaper than the welded one. The material cost is however more expensive and manufacturing is cheaper than the British costs.

It can be concluded that the bolted connections are more economic than the fully welded ones. The calculation is very sensitive to the given data concerning the manufacturing times. These data are different in various companies and countries as well. The scatter can be relatively large between solutions, but making the calculation for a given frame using actual time and cost data, one can get the result and can choose the type of connection.

Since the rotational stiffness of semi-rigid bolted connections is smaller than that of welded ones, the maximum bending moment in an unbraced frame structure is smaller and the beam section can be smaller. The difference between the fabrication costs is significant as well. The disadvantage of bolted connections is the very complicated calculation of rotational stiffness. This causes difficulties in the optimum design of frames with semi-rigid beam-to-column connections. Fabricators prefer welded connections if they are fabricated in workshop, on the other hand, on site, bolted joints are usually cheaper.

Table 4. Summary of costs in \$

Joint	Cost of	Great Britain	South Africa
Welded	Material	563.6	742.00
	Manufacturing	146.3	109.00
	Total	709.9	851.00
Bolted	Material	445.3	605.4
	Manufacturing	218.7	64.3
	Total	664.0	669.7

Acknowledgement

The research work was supported by the Hungarian Scientific Research Foundation grants OTKA T38058 and T37941. The project was also supported by the Hungarian-South African Intergovernmental S&T co-operation program. The Hungarian partner is the Ministry of Education, R&D Deputy Undersecretary of State, the South African partner is the Foundation for Research Development.

References

[1] Eurocode 3. Part 1.8. 2002. Design of joints.

- [2] Witteveen,J., Stark,J.W.B., Bijlaard,F.S.K. & Zoetemeijer,P.: Welded and bolted beam-to-column connections. *J. Struct. Division Proc. ASCE* 108: 1982 (ST2), 433-455.
- [3] Farkas,J., Jármai,K. & Visser-Uys,P. Cost comparison of bolted and welded frame joints. *Welding in the World* 47: 2003 (1/2) 12-18.
- [4] Farkas,J. & Jármai,K. Economic design of metal structures. Rotterdam, Millpress, 2003.
- [5] Al-Salloum,Y.A. & Almusallam,T.H. Optimality and safety of rigidly and flexibly jointed steel frames. *J.Construct.Steel Res.* 35: 1995, 189-215.
- [6] Simões,L.M.C. Optimization of frames with semi-rigid connections. *Computers and Structures* 60: 1996 (4) 531-539.
- [7] Kameshki,E.S. & Saka, M.P. Genetic algorithm based optimum design of nonlinear planar steel frames with various semi-rigid connections. *J. Constructional Steel Research* 59:2003, 109-134.
- [8] Steenhuis,M., Weynand,K. & Gresnigt,A.M. Strategies for economic design of unbraced steel frames. *J. Constructional Steel Research* 46: 1998 (1-3). Paper No.60. CD-ROM.
- [9] ARBED: Profil. Ed. 3-2001.
- [10] Eurocode 3: Design of steel structures. Part 1-1: General structural rules. European Prestandard prEN 1993-1-1: 2002. Brussels, European Committee for Standardisation.
- [11] Farkas,J. & Jármai,K.: Analysis and optimum design of metal structures. Balkema, Rotterdam-Brookfield, 1997.
- [12] Joints in steel construction. Moment connections. The Steel Construction Institute Publ. No. 207. Ascot, UK. 1995.
- [13] ALERT STEEL Pretoria. Price list January 2002.
- [14] Spencer Irving. South African Institute of Steel Construction. Personal communication April 2002.
- [15] Brand,J. Technical instructor. University of Pretoria. Personal communication. April 2002.
- [16] The Screw-man (PTA) (PTY) LTD. Personal communication. April 2002