



Lecture Notes in Mechanical Engineering

Károly Jármái  
Betti Bolló *Editors*

# Vehicle and Automotive Engineering

Proceedings of the JK2016,  
Miskolc, Hungary

 Springer

# Position- and Speed-Dependent, Power-Absorbing Hydraulic Cylinder with Mathematically Predictable Characteristics

Lajos Albrecht, Ferenc Mészáros, Szilárd Szabó and Balázs Barna

**Abstract** Within the framework of the research a position- and speed-dependent, power-absorbing hydraulic cylinder were constructed based on laboratory tests and finite element numerical simulation studies. The elaborated cylinder construction has a mathematically predictable characteristics and based on this feature can be used for different applications in the field of kinetic energy absorbing.

**Keywords** Hydraulic power absorbing · Mathematically predictable characteristics · Articulation system

## 1 Introduction

Utilizing the funds won in tender no. KMOP-1.1.1-08/1-2008-0050, between 2009 and 2013, the associates of SOLID4D Kft. carried out the development of a hydraulic cylinder that is suitable for application as a power-absorbing unit of special characteristics depending on the displacement, with a very simple structure [1]. Its special features and simple structure makes it possible to use this product in a wide range of application areas; for example, in the machine and automotive

---

L. Albrecht (✉)

Mechanical and Transport Engineering, University of Miskolc, Miskolc, Hungary  
e-mail: lajos.albrecht@gmail.com

F. Mészáros

Industrial Engineering, University of Miskolc, Miskolc, Hungary  
e-mail: ferenc.meszaros@innospectrum.hu

S. Szabó

Department of Fluid and Heat Engineering, University of Miskolc, Miskolc, Hungary  
e-mail: aram2xsz@uni-miskolc.hu

B. Barna

Mechanical Engineering, Department of Machine Tools, University of Miskolc, Miskolc, Hungary  
e-mail: barna.balazs@uni-miskolc.hu

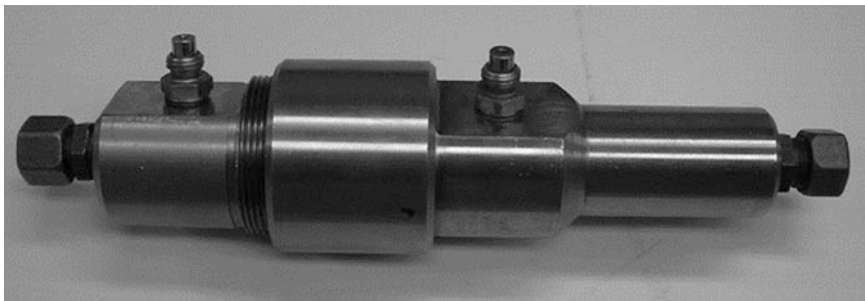
industry, too. In the last 3 years (2013–2016), progress was made in the field of utilization concerning development and production, furthermore, a new type of articulation systems for trailers and sliding articulated buses was tested.

## 2 Theoretical Bases

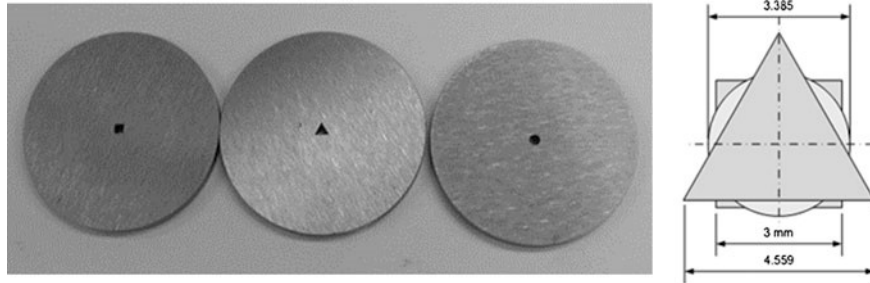
The clarification of theoretical questions and the mathematical formulation of the solution took place as a solution for a problem occurred in connection with a research and development topic. The basic idea was to utilize the dynamic pressure forming during the movement of the piston in the hydraulic cylinders, and to make the dynamic run of the pressure, occurring in the cylinder, predictable by regulating the outflow by a variable gap in the cylinder. The preliminary mathematical analyses revealed the special behaviour according to which, by applying a properly designed, changing throttle gap led by piston displacement, a power-absorbing hydraulic cylinder (bumper, shock absorber) can be created which automatically adapts to the load (depending on the speed and position of the piston). The run of the braking force—as a function of the current speed of the piston—changes automatically so that during its stroke length, the cylinder absorbs the kinetic energy of the colliding object under all circumstances. The forces occurring during the collision process are the smallest possible, i.e. it behaves ideally as a power-absorbing bumper (shock absorber or damper). According to the proposed solution, longitudinal grooves of varying cross section are prepared for the inner wall of the cylinder. Upon loading (displacement of) the piston, the oil flows through these as throttles between the cylinder wall and the piston. By properly creating the cross section of gaps and their axial size distribution, the dynamic load caused by the force affecting the piston bar is of predictable rate, and the displacement and its time course (function) can be determined in advance according to the needs and adjusted to the given technical task.

## 3 Hydraulic Basic Research

As the first step, the numeric and laboratory test of the cross flow factor of gaps in various shapes took place, in order to be able to determine the cross flow factor as a function for hydraulic throttles of different cross section and length; under variable



**Fig. 1** The apparatus serving for receiving resistance bodies with different throttles to be tested, in an assembled status

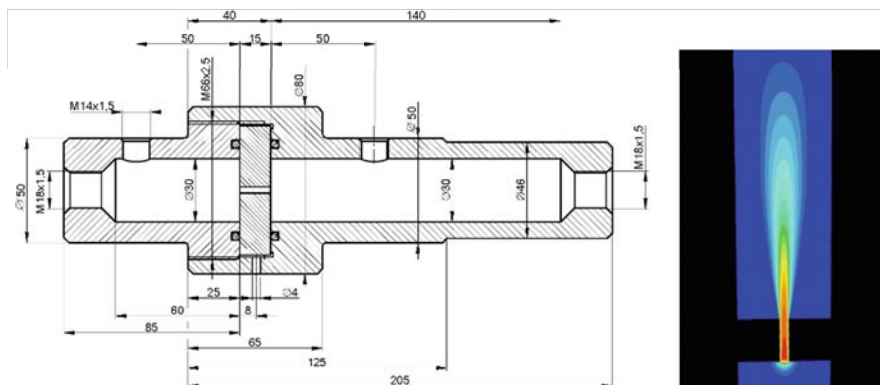


**Fig. 2** Resistance bodies with boreholes of different shape (cushion) and the cross sections of throttles

parameters. For these tests, a measurement tool was prepared with removable discs (Fig. 1), to which we machined gaps of a length of 5, 10 and 15 mm with three different cross sections (triangle, rectangle and circle) (Fig. 2).

The final purpose of the joint performance of the numeric tests and measurements was to control all of the initial parameters for the further numeric simulations. Thus, at the end of the validation process, it is possible to perform the preliminary calculation of new variations by applying the calculations, avoiding the costly manufacture and measurement of a high number of prototypes. The three-dimensional hydrodynamic simulation calculations took place by applying the Ansys Fluent program system [2].

The simulation calculations and the measurements were prepared with the throttles of three different shapes, of lengths of 5, 10 and 15 mm but of the same cross section ( $9 \text{ mm}^2$ ). In Fig. 3, we present the measurement section established for the reception of throttles, which contains the pressure tapings, as well—these are located 50–50 mm before and after the throttles. In order to avoid cavitation, we



**Fig. 3** The drawing of the measurement section containing the throttling element and the flow picture obtained during the simulation calculations

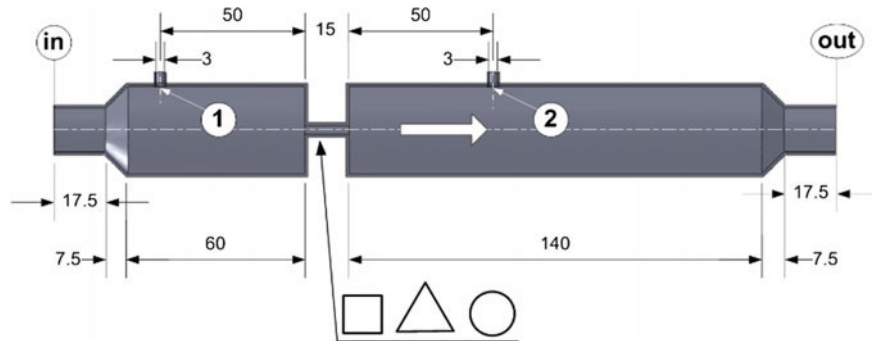


Fig. 4 Geometry of the calculation model

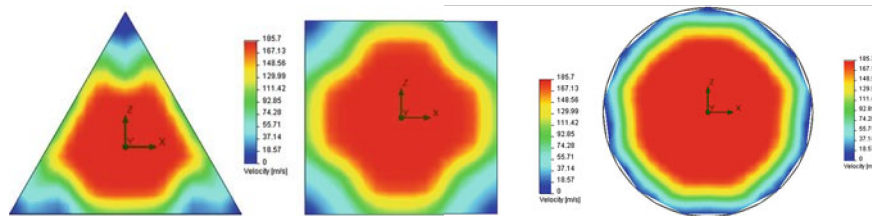


Fig. 5 The speed distributions emerging in the middle plane of boreholes in case of a pressure difference of 60 bar

kept the exiting pressure at a level of  $p_k \approx 30$  bar. Based on the features of the university's testing equipment, pressure differences between  $p \approx 10 \div 80$  bar could be established on the throttles. (Later on, we had the opportunity to perform the control measurements also up to a pressure of 40 bar in the laboratory of a company that deals with the manufacture of hydraulic parts).

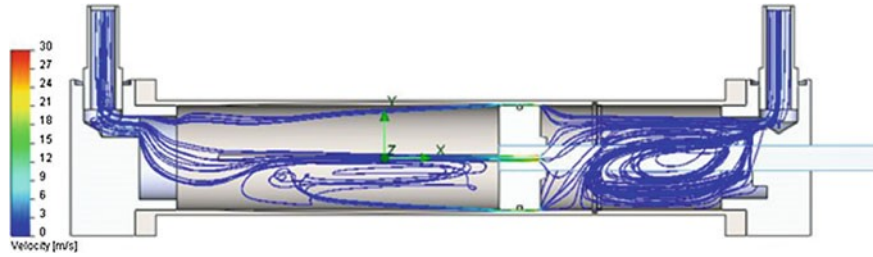
The calculation performed with the Ansys-Fluent flow simulation program [2] took place on the numeric model with the geometry drafted in Fig. 4, which fully corresponds to the surfaces of the measurement section—drafted in Fig. 3—in contact with oil.

During the simulation calculations, we obtained very informative results, for example, in the relatively small gaps, the speed distribution was calculated, as well; showing the dead zones of the flow, as shown in Fig. 5.

The analyses were supported also by the determination of flow conditions formed in the spaces before and after the gaps. The pictures of Fig. 6 show examples of this.

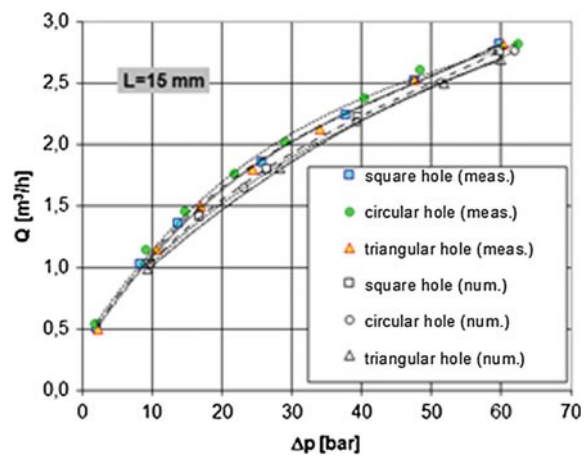
We summarized the results obtained with the calculations and during the measurements in Figs. 7 and 8, with comparative tests.

Figure 7 shows the pressure difference-volume flow diagram prepared based on the measurement and calculation results. Based on the figure, it can be stated that the measured  $Q(\Delta p)$  curves run very close to each other. A slightly higher volume flow is detected only in case of the circle-shaped borehole. In Fig. 8 we can see the

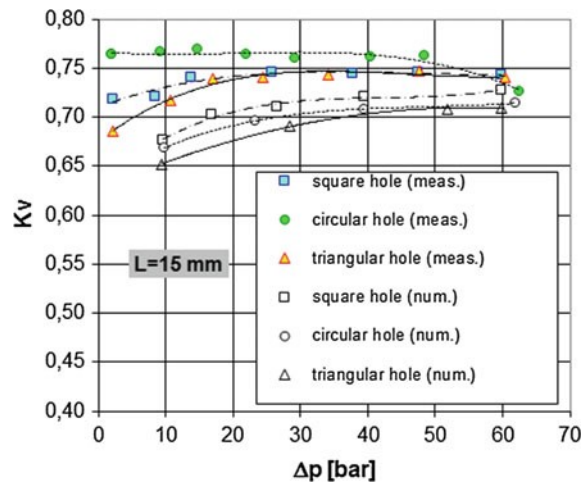


**Fig. 6** Manifestation of speed distributions by trails

**Fig. 7** The measured pressure difference-volume flow curves



**Fig. 8** The measured pressure difference-cross flow factor curves

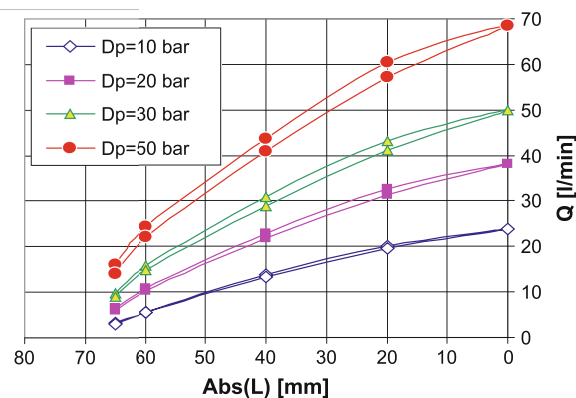


dependence of the  $K_v$  cross flow factor from the pressure difference. In accordance with Figs. 7 and 8 shows that in case of the rectangular and triangular borehole, the measured cross flow factors differ slightly from each other only in case of a small pressure difference. In case of the triangle, here its value is smaller, which can be justified by the corner design of the triangle—unfavourable from the aspect of the flow.

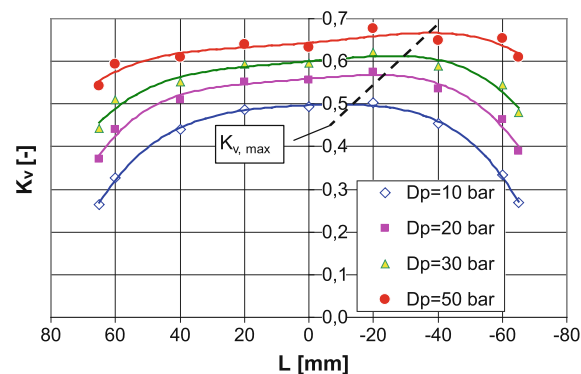
In case of the circular cross section, the cross flow factor moves decisively above the tested range compared to the other cases, and the difference decreases with the increase of the  $\Delta p$  pressure difference. The calculated cross flow factors are 4 ÷ 14% smaller than the measured values. The bigger difference occurs at low volume flows, and the difference gradually decreases with the increase of the volume flow. The differences are not significant, probably during the manufacturing procedures the dimensions are slightly different from the exact values applied at the calculations. A further research task may be the revision and clarification of the geometries applied at the measurement and the calculations and of other determining factors.

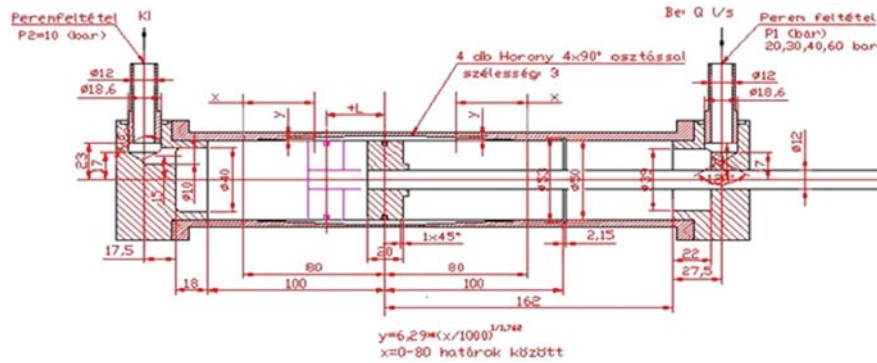
In Figs. 9 and 10, in case of a hydraulic cylinder equipped with a gap of changing cross section, it shows the cross-flown quantities and the cross flow factor

**Fig. 9** Correlation of the L stroke and the Q flow rate in case of various pressure differences



**Fig. 10** The change of the cross-flow factor as a function of the L stroke

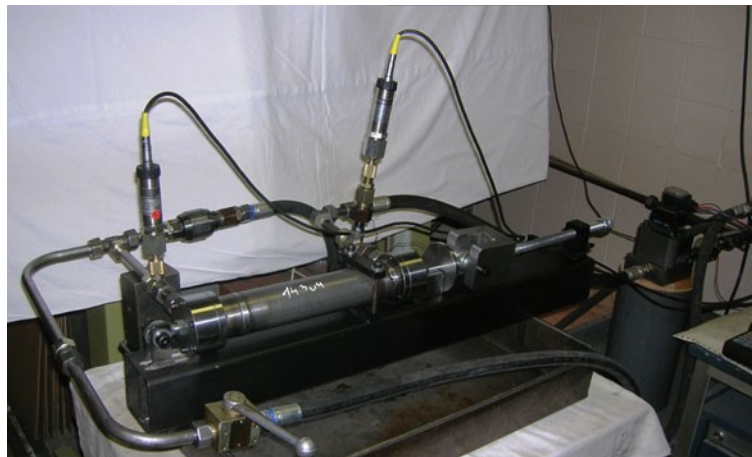




**Fig. 11** Draft of a measurement arrangement enabling variable piston position

as a function of the stroke (piston position) in case of various pressure differences. These measurement results provided the basis for the establishment of the final construction.

In order to be able to draw the diagrams of Figs. 9 and 10, we collected data by using a measurement aid shown in the draft of Fig. 11 and the photo of Fig. 12, furthermore, by measurement arrangement. It was possible to set the position of the piston by the threaded spindle attached to the shaft. After carrying out the cross flow test of the throttling gap of a cross section variable according to the given function, established in the wall of the cylinder and of a length of 160 mm; it became possible to draw the diagrams of Figs. 9 and 10 and to get a picture on the evolution of the cross flow factor depending on the variable geometry of the throttling gap.



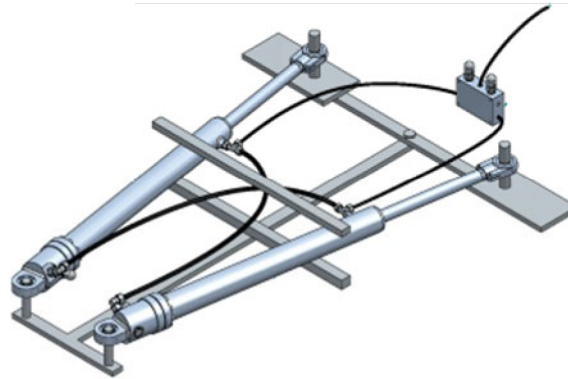
**Fig. 12** The measurement tool and measurement arrangement of cross flow tests

The above described tests—at which the hydraulic simulation was performed by the Department of Flow and Heat Engineering Machines of the University of Miskolc, and the validation was conducted by the Department of Machine Tools on a hydraulic load bench—were completed successfully. The aim of the study was to get information on the dampening effect of the throttling gaps created in the wall of the cylinder, the relationship between the gap size (shape) and the dampening effect, i.e. the behaviour of the so called “cross-flow factor”—usually indicated as a constant—as a function and on its values depending on the changing test parameters. The purpose of the joint performance of measurements and calculations was to find out in what way and with what level of precision is it possible to estimate the throttling effect with numerical simulation.

#### 4 Testing of Prototypes and Steps of Utilization

By using the results of the research performed, several kinds of prototypes were prepared and tested. In addition to the power absorbing hydraulic cylinders of smaller diameter (28 and 50 mm) a complete articulation system was prepared for buses, as well, which is able to replace or exchange those applied currently, with a much simpler and more reliable design. Application for the industrial property right protection has been submitted for this structure, as well. The successful testing of the new-type articulation system took place in July this year (2016), built into a 435-type IKARUS articulated bus. Figure 13 illustrates its sketch. The tests performed are detailed in a related article.

**Fig. 13** Assembly draft of the articulation system



## References

1. Bencs P, Barna B, Makó I, Szabó Sz (2011) Effect of gap geometry on flow losses. In: Proceedings MicroCAD '11 international computer science conference, Section D, Miskolc, Hungary, pp 13–18
2. FLUENT: Fluent V6.2 User's guide. Fluent Inc., Lebanon, New Hampshire, USA, 2005